

6. General Tests for Feed Additives

General Tests includes common methods for the tests and other articles related to them. Unless otherwise specified, liquid chromatography, chloride determination, flame coloration, gas chromatography, loss on drying determination, ultravioletvisible spectrophotometry, congealing point determination, loss on ignition determination, residue on ignition determination, refractive index determination, atomic absorption spectrophotometry, antibacterial determination, microbial assay for antibiotics, digestion determination, 1,4-dioxane determination, heavy metals determination, water determination, microbial identification, microbial enumeration, infrared spectrophotometry, optical rotation determination, crude fat determination, crude fiber determination, nitrogen determination, qualitative test, lead limit determination, bioautography, thin-layer chromatography, pH determination, specific gravity determination, arsenic limit determination, vitamin A assay, vitamin D assay, boiling point and distilling range determination, melting point determination, sulfate limit determination, readily carbonizable substances test, and filter paper chromatography are performed as directed in the corresponding articles under the General Tests.

(1) Liquid chromatography

Liquid chromatography is a method to develop a mixture injected into a column prepared with a suitable stationary phase by passing a liquid as a mobile phase through the column with pump, in order to separate the mixture into its components by making use of the difference of retention capacity against the stationary phase, and to determine the components. This method can be applied to a liquid or soluble sample, and is used for identification, purity test, and quantitative determination.

A mixture injected into the column is distributed between the mobile phase and the stationary phase with a characteristic ratio for each component. The ratio k' represents the mass distribution ratio.

$$k' = \frac{\text{amount of compound in the stationary phase}}{\text{amount of compound in the mobile phase}}$$

Between the mass distribution ratio and the retention time t_R (time between the sample injection time and the top of the peak), because there is a relationship to the next, in the same column, the retention time for a compound on a column has a characteristic value under fixed chromatographic conditions of column temperature, components of the mobile phase and flow rate.

$$t_R = (1 + k') t_0$$

t_0 : time measured from the time of injection of a compound with $k' = 0$ to the time of elution at the peak maximum

Apparatus:

Basically, the apparatus required for the liquid chromatographic procedure consists of a pumping system for mobile phase, a sample injection port, a column, a detector, and a recorder. A column is maintained at a constant temperature by a thermostat, if necessary. The pumping system is serves to deliver the mobile phase into the column and connecting tube at a constant flow rate. The column is a tube of 2~8 mm in diameter and 10~100 mm in length, in which a packing material for liquid chromatography of particle size 3~50 μm is uniformly packed.

Unless otherwise specified, resolution, R_S , defined in the following equation, is specified in each monograph.

$$R_S = \frac{2(t_{R1} - t_{R2})}{1.67(W_{h1} + W_{h2})}$$

t_{R1} , t_{R2} : Retention times of two compounds used for the measurement of resolution.

W_{h1} , W_{h2} : Peak widths at half peak height.

Usually, the detector is used to detect a property of the samples which is different from that of the mobile phase, and may be an ultraviolet or visible spectrophotometer, differential refractometer, fluorometric detector, etc. The output signal is proportional to the concentration of samples at amounts of less than a few μg . The recorder is used to record the output signals of the detector.

Procedure:

Fix the detector, column and mobile phase to the apparatus, and adjust the flow rate and the column temperature to the values described in the operating conditions specified in the individual monograph. Inject a volume of the sample solution specified in the individual monograph with a microsyringe or the sample valve into the column through the sample injection port. The separated components are detected by the detector, and recorded by the recorder as a chromatogram. Identification is performed by confirming identity of the retention time, or by confirming that the peak shape is unchanged after mixing the standard sample. Quantitative determination is usually performed by using internal standard method, in the case of that an appropriate internal standard substances is not obtained, it is performed by using absolute calibration curve method.

A. Internal standard method

In the internal standard method, choose a chemically stable compound as an internal standard which shows a retention time close to that of the compound to be assayed, and whose peak is well separated from all other peaks in the chromatogram. Prepare several kinds of standard solutions containing a fixed amount of the internal standard and several graded amounts of the authentic specimen specified in the individual monograph. Based on the chromatogram obtained by injection of a fixed volume of individual standard solutions, calculate the ratio of peak area of peak height of the authentic specimen to that of the internal

standard, and prepare a calibration curve by plotting these ratios on the ordinate against the amount of the authentic specimen or the ratio of the amount of the authentic specimen to that of the internal standard on the abscissa. The calibration curve is usually obtained as a straight line passing through the origin. Then, prepare a sample solution containing the internal standard in the same amount as in the standard solutions used for the preparation of the calibration curve according to the method specified in the individual monograph, perform the liquid chromatography under the same operating conditions as for the preparation of the calibration curve, calculate the ratio of the peak area or peak height of the objective compound to that of the internal standard, and read the amount of the compound from the calibration curve.

B. Absolute calibration curve method

Prepare standard solutions with several graded amounts of the authentic specimen, and inject accurately a fixed volume of these standard solutions. With the chromatogram obtained, prepare a calibration curve by plotting the peak areas or peak heights on the ordinate against the amount of the authentic specimen on the abscissa. The calibration curve is generally obtained as a straight line passing through the origin. Then, prepare a sample solution according to the method specified in the individual monograph, perform the liquid chromatography under the same conditions as for the preparation of the calibration curve, measure the peak area or peak height of the objective compound, and read the amount of the compound from the calibration curve.

Generally, the following methods are used.

A. Peak height measuring method

Measure the distance between the maximum of the peak and the intersecting point of a perpendicular line from the maximum of the peak to the horizontal axis of recording paper with a tangent linking the baselines on both sides of the peak.

B. Peak area measuring method

- (a) Width at half-height method: Multiply the peak width at the half-height by the peak height.
- (b) Automatic integration method: Measure the signals from the detector as the peak area using a data processing system.

(2) Chloride Limit Test

Chloride Limit Test is a limit test for chloride contained in samples.

In each monograph, the permissible limit for chloride (as Cl) is described in parentheses.

Procedure:

Unless otherwise specified, proceed as follows.

Transfer the quantity of the sample, directed in the monograph, to a Nessler tube, and dissolve it in a proper volume of water to make 40 mL. Add 6 mL of dilute nitric acid and water to make 50 mL, and use this solution as the sample solution. Measure the volume of 0.01 mol/L hydrochloric acid directed in the monograph, to another Nessler tube, add 6 mL of dilute nitric acid and water to make 50 mL, and use this solution as the control solution. When the sample solution is not clear, filter both solutions by using the same procedure.

Add 1 mL of silver nitrate test solution to the sample solution and to the control solution, mix well, and allow to stand for 5 minutes protecting from light. Compare the opalescence developed in both solutions against a black background by viewing downward or transversely.

The opalescence developed in the test solution is not more than that of the control solution.

(3) Flame Coloration Test

Flame Coloration Test is a method to detect an element, by means of the property that the element changes the colorless flame of a Bunsen burner to its characteristic color.

Procedure:

The platinum wire used for Flame Coloration Test is about 0.8 mm in diameter, and the end part of it is straight. In the case of solid sample, make the sample into a gruel by adding a small quantity of hydrochloric acid, apply a little of the gruel to the 5 mm end of the platinum wire, and test by putting the end part in a colorless flame, keeping the platinum wire horizontal. In the case of a liquid sample, immerse the end of the platinum wire into the sample to about 5 mm in length, remove from the sample gently, and perform the test in the same manner as for the solid sample.

The description, "Flame coloration persists", in a monograph, indicates that the reaction persists for about 4 seconds.

(4) Gas Chromatography

Gas Chromatography is a method to develop a mixture injected into a column prepared with a suitable stationary phase by passing a gas (carrier gas) as a mobile phase through the column, in order to separate the mixture into its components, and to determine the components. This method can be applied to a gaseous or vaporizable sample, and is used for identification, purity test, and quantitative determination.

In the case of using absorbed carriers with appropriate particle size as the stationary phase, is called gas-solid chromatography. In the case of using inert carrier with appropriate particle size coated with a liquid phase or the capillary whose inner wall is coated with a liquid phase, is called gas-liquid chromatography.

Apparatus:

Basically, the apparatus required for the gas chromatographic procedure consists of a carrier gas-introducing port, a sample injection port, a column, a column oven, a detector and a recorder.

Procedure:

Unless otherwise specified, proceed by the following method.

Fix the column, detector and the column temperature, and adjust the flow rate to the values described in the operating conditions specified in the individual monograph.

Inject a volume of the sample solution or the standard solution specified in the individual monograph with the sample injector into the column system through the sample injection port. The separated components are detected by the detector, and recorded by the recorder as a chromatogram.

A peak position of the components on the chromatogram is expressed in the retention time (time measured from the time of injection of a compound to be determined to the time of elution at the peak maximum), or the retention volume (the retention time \times the flow rate of carrier gas). The retention time and the retention volume for a compound on a column have a characteristic value under fixed chromatographic conditions. The identification of the sample components can be determined by this method. In addition, assay is proceeded by using the peak area, the peak height and etc., of the components on the chromatogram.

Assay is usually proceeded by any of the following methods.

A. Internal standard method

Prepare standard solutions containing a fixed amount of the internal standard and several graded amounts of the authentic specimen specified in the individual monograph. Based on the chromatogram obtained by injection of a fixed volume of individual standard solutions, calculate the ratio of peak area or peak height of the authentic specimen to that of the internal standard, and prepare a calibration curve by plotting these ratios on the ordinate against the amount of the authentic specimen or the ratio of the amount of the authentic specimen to that of the internal standard on the abscissa.

Then, prepare a sample solution containing the internal standard in the same amount as in the standard solutions used for the preparation of the calibration curve according to the method specified in the individual monograph, perform the liquid chromatography under the same operating conditions as for the preparation of the calibration curve, calculate the ratio of the peak area or peak height of the objective compound to that of the internal standard, and read the amount of the compound from the calibration curve.

In the internal standard method, choose a chemically stable compound as an internal standard which shows a retention time close to that of the compound to be assayed, and whose peak is well separated from all other peaks in the chromatogram.

B. Absolute calibration curve method

Prepare standard solutions with several graded amounts of the authentic specimen, and inject accurately a fixed volume of these standard solutions. With the chromatogram obtained, prepare a calibration curve by plotting the peak areas or peak heights on the ordinate against the amount of the authentic specimen on the abscissa. Then, prepare a sample solution according to the method specified in the individual monograph, perform the liquid chromatography under the same conditions as for the preparation of the calibration curve, and read the amount of the compound from the calibration curve. In this method, all procedures must be carried out under a strictly constant condition.

C. Peak area percentage method

The peak area percentage method is a method to calculate the proportion of the components from the ratio of the peak area of each component to the sum of the peak areas of every peak recorded in the chromatogram. In order to obtain accurate results in evaluating the proportion of the components, it is necessary to correct the area of each component based on its relative response factor to the principal component.

The peak area percentage method is usually proceeded by any of the following methods.

Peak height measuring method**A. Peak height measuring method**

Measure the distance between the maximum of the peak and the intersecting point of a perpendicular line from the maximum of the peak to a tangent linking the baselines on both sides of the peak.

B. Peak area measuring method

(a) Width at half-height method: Multiply the peak width at the half-height by the peak height.

(b) Automatic integration method: Measure the peak area by using a digital integrator, etc.

(5) Loss on Drying Test

Loss on Drying Test is a method to measure the loss in mass of the sample, when dried under the conditions specified in each monograph. This method is applied to determine the amount of water, all or a part of water of crystallization, or volatile matter in the sample, which is removed during the drying.

The description, for example, “not more than 1.0 % (1 g, 105 °C, 4 hours)” in a monograph, indicates that the loss in mass is not more than 10 mg per 1 g of the substance in the test in which about 1 g of the substance is weighed down to the degree of 0.1 mg and recorded its value, and dried at 105 °C for 4 hours, and ”not more than 0.5 % (1 g, in vacuum, phosphorus (V) oxide, 4 hours)”, indicates that the loss in mass is not more than 5 mg per 1 g of the substance in the test in

which about 1 g of the substance is weighed down to the degree of 0.1 mg, transferred into a desiccator (phosphorus (V) oxide), and dried in vacuum for 4 hours.

Procedure:

Weigh a weighing bottle, that has been dried for 30 minutes according to the method specified in the monograph, down to the degree of 0.1 mg, and recorded the value. Take the sample within the range of $\pm 10\%$ of the amount directed in the monograph, transfer into the weighing bottle, and, unless otherwise specified, spread the sample so that the layer is not thicker than 5 mm, then weigh it down to the degree of 0.1 mg, and record the value. Place the loaded bottle in a drying chamber, and dry under the conditions specified in the monograph. When the size of the sample is large, convert it to small particles having a size not larger than 2 mm in diameter by quick crushing, and use the crushed sample for the test. After drying, remove from the drying chamber, and reweigh down to the degree of 0.1 mg. When the sample is dried by heating, the temperature is within the range of $\pm 2\text{ }^{\circ}\text{C}$ of that directed in the monograph, and, after drying the bottle, the sample is allowed to cool in a desiccator (silica gel), weigh it down to the degree of 0.1 mg, and record the value. If the sample melts at a temperature lower than that specified in the monograph, expose the sample for 1 to 2 hours to a temperature between $5\text{ }^{\circ}\text{C}$ and $10\text{ }^{\circ}\text{C}$ below the melting temperature, dry under the conditions specified in the monograph. Use a desiccant specified in the monograph, and renew frequently.

(6) Spectrophotometry

Spectrophotometry is a method to measure the degree of absorption of light between the constant narrow wavelength ranges. When monochromatic light passes through a substance in the solution, the ratio of transmitted light intensity I to incident light intensity I_0 is called transmittance t transmittance expressed in the percentage is called percent transmission T , and common logarithm of the reciprocal of transmittance is called absorbance A .

$$t = \frac{I}{I_0} \quad T = \frac{I}{I_0} \times 100 = 100 t \quad A = \log \frac{I_0}{I} = -\log t = 2 - \log T$$

When a light beam passes through a substance in the solution, the absorbance by the sample differs depending on the wavelength of the light. So, an absorption spectrum is obtained by determining the absorbances of a light beam at various wavelengths and by graphically plotting the relation between absorbance and wavelength. From the absorption spectrum, it is possible to determine the wavelength of maximum absorption λ_{max} and that of minimum absorption λ_{min} .

The absorption spectrum of a substance in the solution is characteristic, depending on its chemical structure. Therefore, it is possible to identify a substance, or determine its purity by determining the wavelengths of maximum absorption or minimum absorption, or by measuring

the ratio of absorbances at two specified wavelengths. For the purpose of assay, the absorbance by a sample solution with a certain concentration is measured at the wavelength of the maximum absorption.

The absorbance A is proportional to the concentration c of a substance in the solution and the length l of the layer of the solution through which light passes.

$$A = kcl$$

The absorbance, calculated on the basis that l is 1 cm and c is 1 w/v%, is called specific absorbance $E_{1\text{cm}}^{1\%}$, and the absorbance, calculated on the basis that l is 1 cm and c is 1 mol/L, is called molar absorption coefficient ϵ . The molar absorbance coefficient at the maximum absorption is expressed as ϵ_{max} .

$$E_{1\text{cm}}^{1\%} = \frac{A}{c(\%) \times l} \quad \epsilon = \frac{A}{c(\text{mol}) \times l}$$

l : Length of the layer of the solution (cm)

A : Absorbance value

c (%): Concentration of the sample in the solution (w/v%)

c (mol): Molar concentration of the sample in the solution (mol/L)

Apparatus:

A photoelectric spectrophotometer is used for the measurement of absorbance. As the light source, a tungsten lamp for visible range and a hydrogen discharge lamp or a deuterium discharge lamp for ultraviolet range, is used. Unless otherwise specified, a cell with a path length of 1 cm, made of quartz for ultraviolet range and of quartz or glass for visible range, is used.

Procedure:

Adjust the wavelength dial to the directed wavelength, and adjust the dark current to zero, place the cell containing the sample solution in the light path, open the shutter, and adjust the absorbance to zero. For the control solution, unless otherwise specified, blank solvent is used. Then perform the measurement with the cell containing the sample solution, and read the absorbance at measuring wavelength. In the case of directing the measuring wavelength range, perform the measurement according to it.

Special consideration is needed with the absorption of solvents in the ultraviolet range; use a solvent which does not disturb accurate measurement. The calibration of the wavelength and the absorbance dial is carried out as follows.

The wavelength dial is usually calibrated by the use of the wavelength such as 239.95 nm, 253.65 nm, 302.15 nm, 313.16 nm, 334.15 nm, 365.48 nm, 404.66 nm, 435.83 nm or 546.10 nm for a quartz mercury arc lamp or a glass mercury arc lamp, or 486.13 nm or 656.28 nm for a hydrogen discharge lamp, or 486.02 nm or 656.10 nm for a deuterium discharge lamp.

The absorbance dial is calibrated by the use of the solution which is prepared by dissolving potassium dichromate (standard reagent) in 0.005 mol/L sulfuric acid to make 0.006 v/w% potassium dichromate. $E_{1\text{ cm}}^{1\%}$ of this solution is 125.2, 145.6, 48.9 and 107.0 for the wavelength of 235 nm (minimum), 257 nm (maximum), 313 nm (minimum) and 350 nm (maximum), respectively.

(7) Congealing Point Determination

Congealing point is a temperature which becomes constant when the procedure is run as follows.

Apparatus:

Use the apparatus illustrated in figure.

- A. Cylinder: It is made of glass, and painted with silicone oil on both sides of the wall to prevent clouding.
- B. Sample Container: A hard glass test tube, which is painted with silicone oil to prevent clouding, except at the region of the wall in contact with the sample.

Insert it into cylinder A, and fix with cork stopper.

- C. A marked line
- D. Bath: It is made of glass.
- E. Stirring rod: It is made of glass, 3 mm in diameter, the lower end part of it is bent to make a loop, about 18 mm in diameter.
- F. Thermometer: No. 4 ~ No. 6.
- G. Thermometer: No.1 or No. 2.
- H. Auxiliary thermometer: Use the thermometer No.1, the mercury bulb is located in the center of between the top of the sample and the reading of thermometer F (congealing point).

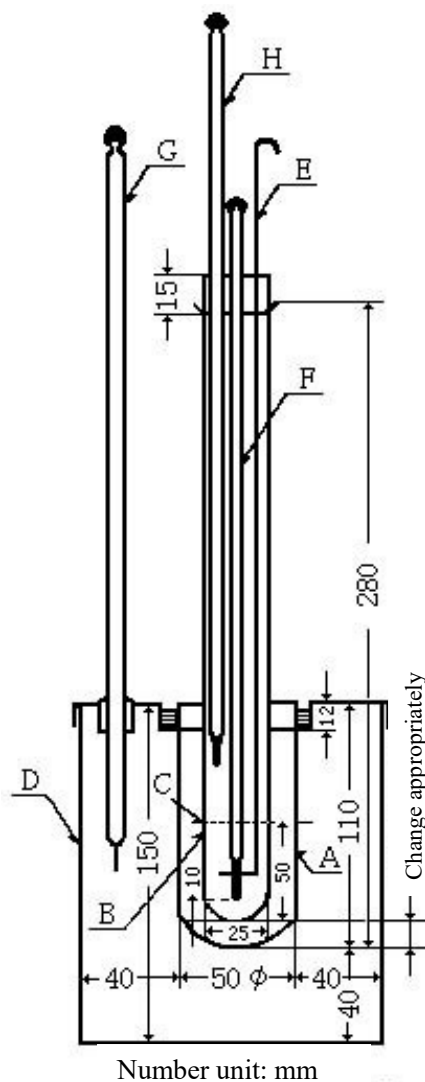

Bath Liquid:

Heating liquid: Water, glycerin, tricresyl phosphate, vegetable oil, and sulfuric acid, etc., are available.

If the sample is solid at room temperature, in addition to figure, provide a heating bath. The shape, the material, etc., are available.

Cooling liquid: Use the followings according to the congealing point.

Not less than 80 °C: Glycerin, tricresyl phosphate, vegetable oil, etc., are available.

80~0 °C: Water or ice.

0 ~-10 °C: Crushed ice and sodium chloride, or methyl alcohol and dry ice.

Procedure:

A. In case of the solid sample at room temperature

Place the dried sample in the clean and dried sample container B to adjust the level of the surface of the liquid to the marked line C when the sample is melting, and carefully heat to a temperature not higher than 20 °C above the expected congealing point. After melting the sample completely, remove it from the bath, insert the thermometer F, the auxiliary thermometer H and the stirring rod as shown in figure, fix with the cork, immerse in a cooling bath with cooling liquid at a temperature about 5 °C below the expected congealing point.

Move vertically the stirring rod, after cooling the sample to about 5 °C above the expected congealing point, move vertically the stirrer at the rate of about 20 ~ 30 strokes per minute, and observe the thermometer readings at 30 second intervals.

The temperature falls gradually at first, Discontinue stirring, when an appreciable amount of crystals has formed and the temperature is constant or has begun to rise. Observe the thermometer readings at 10 second intervals, read the maximum temperature (reading of F and H), that is constant for one minute after a rise of temperature. The constant point is calculated according to the following equation.

$$T = t + 0.00016 (t - t') n$$

T: Congealing point (°C)

t: Reading of the thermometer (°C)

t': Reading of the auxiliary thermometer (°C)

n: Frequency of the outside the liquid of a thermometer mercury line (°C)

B. In the case of the liquid sample at room temperature

Place the dried sample in the clean and dried container B to adjust the level of the surface of the liquid to the marked line C. Insert the thermometer F, the auxiliary thermometer H and the stirring rod as shown in the figure, fix with the cork, immerse in a cooling bath with cooling liquid at a temperature about 5 °C~10 °C below the expected congealing point. Proceed in the same manner as for the solid sample.

(8) Loss on Ignition Test

Loss on Ignition Test is a method to measure the loss in mass when the sample is ignited under the conditions specified in each monograph. This method is usually applied to inorganic articles which lose a part of the components or impurities during ignition. The description, for example, “40.0~52.0 % (1 g, 450~550 °C, 3 hours)” in a monographs, indicates that the loss in mass is 400 to 520 mg per g of the substance in the test in which about 1 g of the substance is weighed down to the degree of 1 mg and recorded the value, and ignited between 450 °C and 550 °C for 3 hours.

Procedure:

Previously ignite a crucible or a dish of platinum, quartz or porcelain to constant mass, at the temperature directed in the monograph, weigh it to three decimal places and record the value after cooling.

Take the sample within the range of ± 10 % of the amount directed in the monograph, transfer into the above ignited container, and weigh it to three decimal places and record the value. Ignite under the conditions directed in the monograph, and cool, reweigh down to the degree of 1 mg, and record the value. A desiccator (silica gel) is used for cooling.

(9) Residue on Ignition Test

The residue on Ignition Test is a method to measure the amount of residual substances not volatilized from the sample when the sample is ignited according to the procedure described below. This test is usually used for determining the content of inorganic impurities in an organic substance. In some cases, it is used for determining the amount of inorganic substances contained as the components in an organic substance, or impurities in an inorganic substance volatilized while hot. The description, for example, “not more than 0.1 % (1 g)”, in the monograph, indicates that the mass of the residue is not more than 1 mg per 1 g of the substance in the test in which about 1 g of the substance is weighed down to the degree of 0.1 mg and recorded the value, and ignited by the procedure described below, and “after drying” indicates that the sample is tested after being dried under the conditions specified in the test for Loss on drying.

Procedure:

Ignite previously a crucible of platinum, quartz or porcelain between 450 °C and 550 °C until it becomes a constant mass. Cool the crucible, weigh down to the degree of 0.1 mg and record the value.

Take the sample within the range of ± 10 % of the amount directed in the monograph, transfer into the above ignited container, and weigh to one decimal place and record the value. Moisten the sample with a small amount of sulfuric acid, then heat gently at a temperature as low as practicable until the sample is thoroughly charred or evaporated. After cooling, moisten the

residue with a small amount of sulfuric acid, heat gently until white fumes are no longer evolved, and ignite between 450 °C and 550 °C until the residue is completely incinerated. Cool, weigh down to the degree of 0.1 mg and record the value. A desiccator (silica gel) is used for cooling. In the case of the residue on ignition specified in the monograph is prescribed as not more than % or not more than mg, and the amount of residue obtained exceeds the above value, or in the case of the residue on ignition prescribed within a certain range, repeat the ignition until it becomes a constant mass.

(10) Refractive Index Determination

Refractive index of substance is the ratio of velocity of the light in vacuum to that of substance, and is equal to the ratio of sine of the angle of incidence of the light to the substance, to that of the angle of refraction. Generally, the refractive index is influenced by the wavelength of the light and the temperature.

The refractive index is given in the value relative to the air, and the D line of the sodium spectrum is used for irradiation. When the measurement is carried out at t °C, this value is expressed as n_D^t .

Procedure:

For the measurement of refractive index, usually the Abbé refractometer is used at a temperature in the range of ± 0.2 °C of that directed in the monograph.

(11) Atomic Absorption Spectrophotometry

Atomic Absorption Spectrophotometry is a method to determine the amount (the concentration) of an element in a sample specimen being examined, by utilizing the phenomenon that atoms being in the ground state absorb the light of specific wavelength when the light passes through an atomic vapor layer.

Apparatus:

Usually, the apparatus consists of a light source, a sample atomizer, a spectroscope, a photometer and a recording system. Some are equipped with a background compensation system. As a light source, usually a hollow cathode lamp specified for each element is used and sometimes a discharge lamp is also used. There are two types of sample atomizer: the flame type and the flameless type (the electrothermal type, and the cold-vapor type). The flame-less type is classified into two subtypes, which differ in the reduction-vaporization method and the thermal-vaporization method. The flame type is composed of a burner and a gas-flow regulator, the electrothermal type is composed of an electric furnace and a power source, and the cold-vapor type is composed of a mercury generator and an absorption cell. For a spectroscope, a grating for light diffraction or an

interference filter can be used. A photometer is composed of the detector and the signal processing system. A recording system is composed of a display and a recording device. A background compensation system is employed for the correction of atmospheric effects on the measuring system. Several principles can be utilized for background compensation, using continuous spectrum sources, the Zeeman splitted spectrum, the nonresonance spectrum, or self-inversion phenomena.

Procedure:

Unless otherwise specified, proceed by any of the following methods.

A. Frame type

Fit the specific light source to the lamp housing and switch on the instrument. After lighting the lamp and selecting the analytical wavelength specified in the monograph, set an appropriate electric current and slit-width. Next, a mixture of a combustible gas and a supporting gas is ignited and the gas flow rate and/or pressure should be adjusted to optimum conditions. The zero adjustment of the detecting system must be done through nebulizing the blank solvent into the flame. After setting up the measuring system, the sample solution prepared by the specified procedure is introduced into the flame and the absorbance is measured.

B. Frameless type (Electrothermal type)

Fit the specific light source to the lamp housing and switch on the instrument. After lighting the lamp and selecting the analytical wavelength specified in the monograph, set an appropriate electric current and slit-width. Further, a suitable amount of the sample solution or standard solution as directed separately in the monograph is injected into the heated furnace with an appropriate inert gas, set an electric furnace to the appropriate temperature, electric current, and heating program, the sample is dried and ashed, and the absorbance is measured.

C. Frameless type (Cold-vapor type)

Fit the mercury lamp to the lamp housing and switch on the instrument. After lighting the lamp and selecting the analytical wavelength specified in the monograph, set an appropriate electric current and a slit-width. In the reduction-vaporization method, place the sample solution or standard solution into the closed vessel, reduce to the element by adding a proper reducing reagent, and vaporize. In the thermal-vaporization method, the sample specimen is heated and vaporized, measure the absorbance of the generated atomic mercury vapor.

Usually, proceed by any of the following methods. In the determination, the possibility of interference for various reasons and the background effect must be considered and avoided if possible.

A. Calibration curve method

Prepare standard solutions at more than 3 concentration levels, measure the specific absorption due to these standard solutions, and prepare the calibration curve of the atomic absorption against the concentration. Then measure the atomic absorption due to the sample specimen, in which the concentration of the element to be determined should be adjusted to be within the concentration range of the standard solutions, and determine the amount or the concentration of the element to be examined using the calibration curve.

B. Standard addition method

To equal volumes of more than 3 sample solutions, prepared as directed in the monograph, add a measured quantity of the standard solutions to produce a series of solutions containing increasing amounts of the element to be examined, and further add a solvent to make up a constant volume. Measure the atomic absorption for the respective solutions, and plot the obtained values on a graph with the added amount or the concentration on the abscissa and the absorbance on the ordinate. Extrapolate the linear plot obtained by linking the data points, and determine the amount or the concentration of the element to be examined from the distance between the origin and the point where the plot intersects with the abscissa. This method is available only when the calibration curve obtained by Method A. is confirmed to be linear and to pass through the origin.

C. Internal Standard Method

Prepare a series of standard solutions of the element to be determined, each containing a definite amount of the internal standard element directed in the monograph. For these standard solutions, measure the atomic absorption due to the standard element and the internal standard element separately at the respective wavelengths under the same operating conditions, and obtain the ratio of absorbance by the standard element to that by the internal standard element. Prepare a calibration curve for the element to be determined, with the amount or the concentration of the standard element on the abscissa and the above-mentioned ratio of the absorbance on the ordinate. Then prepare sample solutions, adding the same amount of the internal standard element as contained in the standard solutions. Measure the ratio of the absorbance due to the element to be determined to that due to the internal standard element under the same conditions as employed for preparing the calibration curve, and determine the amount or the concentration of the element being examined by using the calibration curve.

Note: Reagents, test solutions, and gases used in this test should not interfere in any process of the measurement.

(12) Antimicrobial Activity Test Method

Antimicrobial activity test method is a test method that measures presence or absence of antimicrobial activity for an enzyme feed additive product by a biological method. Water, reagents, test solutions, measuring instruments, containers, and discs used for this test are germfree as needed.

Test equipment:

Use disks with 10 mm diameter and a membrane filter with a pore size of 0.45 µm. A petri dish is made of hard glass or synthetic resin with 90 mm inner diameter and 20 mm height, and bottom is smooth. Use a matching lid with this.

Types of medium, the composition and, pH:

Except otherwise specified, use with the composition and pH listed in the following table.

Composition of medium and pH

Medium number		1	2	3
Composition of medium in 1,000mL	Peptone (g)	10		
	Meat extract (g)	5		
	Salt (g)	2.5	5	5
	Glucose (g)		2.5	
	Casein digested in pancreas (g)		17	15
	Papain digestion bean (g)		3	5
	Potassium hydrogen phosphate (g)		2.5	
	Agar (g)	13-15		13-15
	Distilled water	Proper quantity	Proper quantity	Proper quantity
	pH after sterilization	6.5±0.1	7.3±0.1	7.3±0.1

Preparation of the test bacterial solution:

- A. *Micrococcus luteus* for ATCC 9341 and *Escherichia coli* for ATCC 27166, transplant repeatedly in about one week intervals to the No. 1 medium, and transplant inoculum passaged to save for use while pure culturing at 35~37 °C. Thereafter, static culture is performed for 22~24 hours at 35~37 °C and test bacteria solution is created by shaking well.
- B. *Bacillus subtilis* for ATCC 6633, transplant repeatedly in about three week intervals to the No. 1 medium, and transplant inoculum passaged to save for use while pure culturing at 35~37 °C, transferred to the same medium in a roux bottle. And spores are produced by culturing for one week at 35~37 °C. Scrape bacterial plaque, and suspend uniformly in appropriate amount of water. Discard the supernatant by 30 minutes centrifugation at 3,000 rpm, and shake by adding appropriate amount of water, then, heat two times for 20 minutes at 65 °C for 24 hours intervals. Collect the supernatant by centrifugation for 5 minutes at 1,000 rpm, and prepare the spore suspension of suitable concentration by calculating the

spore count. Prepare the spore suspension of 1×10^6 cfu/mL by diluting the spore suspension with water, and this is defined as test bacterial solution.

Preparation of plate medium:

Weigh 1.5 mL of each test bacterial solution three types, and dissolve once. Add 13.5 mL to the No. 3 medium being cooled to temperature that does not inhibit the vitality of the test organism. After blending, thoroughly to pour into a sterile petri dish and the medium is solidified by standing horizontally.

Procedure:

Add 9 mL of water to 1 g of sample, shake well, and centrifuge for 5 min at 3,000 rpm. Use the supernatant sterilized by filtration through membrane filter as the sample solution. Absorb 0.1 mL of the sample solution sufficiently into six discs, and place each two discs to become the opposite angle on plate medium of three types. In addition, absorb 0.1 mL of water sufficiently into six discs, and place two discs to become each top of the square. Leave for 2 hours in cold. Next, culture for 22~24 hours at 35~37 °C, and observe for the presence or absence of growth inhibition circle around the discs.

Judgment criteria:

When confirming clear growth inhibition zone having with 12 mm or more diameter, it is assumed that exhibit antimicrobial activity is indicated.

(13) Titer Test Method for Antibiotic

Titer test method is a test method by measuring titer of antibiotic feed additives by biological method or chemical method. Except otherwise specified, the tests is performed by the following method. Water, reagents, test solutions, meters, and containers for this test are germfree for use.

Cylinder (cup):

Use stainless steel with 7.9~8.1 mm outer diameter, 5.9~6.1 mm inner diameter, and 9.9~10.1 mm height. The cylinder must not be prevented from interfering the test.

Types of medium, composition, and pH:

Except otherwise specified, use ones having the composition and pH listed in the following table. However, in the case of specifying "peptone" simply as a component of the medium, there is no problem using either casein peptone or proteose peptone. Use 1 mol/L hydrochloric acid test solution or 1 mol/L sodium hydroxide test solution for the adjustment of pH of the medium, the pH after sterilization shall be specified. Sterilization is performed for 20 minutes at 121 °C by using a high-pressure steam sterilizer. However, the medium of *Bacillus subtilis* ATCC 6633 is prepared by using ammonia test solution, potassium hydroxide test solution, or 1 mol/L hydrochloric acid test solution. Dehydrated culture media of off-the-shelf has the same component

as the media prepared according to the composition of each prescription, and it can be used in the case of indicating the performance and growth of the test bacteria equivalent.

Composition of medium and pH

Medium number	1	2	3	4	5	6	7	8	9	10	11	12	13	14	15	16	17	18	19
Peptone (g)	10	10	5	6	6	10	6			10	5	3.75	5	5		10	10		
Proteose peptone (g)																			6
Casein pepton (g)																			4
Meat extract (g)	5	5	3	1.5	1.5	5	1.5			10			5	3		5	5	1.5	
Sodium chloride (g)	2.5	2.5			2.5	2.5		5	5	5		1.25	80			2.5	2.5		50
Yeast extract (g)				3	3		3					1.25			2.5			3	2.5
Glucose (g)				1	1	5	1	2.5	2.5		5				1			1	10
Polysorbate 80 (mL)									10							0.4			
Casein digested in pancreas (g)								17	17										
Papain digestion bean (g)								3	3										
Papain digestion liver (g)												0.625							
Potassium dihydrogen phosphate (g)															0.45				
Potassium hydrogen phosphate (g)								2.5	2.5						0.69				
Sodium hydrogen phosphate 12-wate (g)													2						
Magnesium fulfate (g)																			50
Agar (g)	13-20		13-20	13-20	13-20	13-20	13-20	13-20	13-20	13-20	13-20	13-20	13-20	13-20	13-20	13-20	13-20	13-20	13-20
Water (g)	Proper quantity	Proper quantity	Proper quantity	Proper quantity	Proper quantity	Proper quantity	Proper quantity	Proper quantity	Proper quantity	Proper quantity	Proper quantity	Proper quantity	Proper quantity	Proper quantity	Proper quantity	Proper quantity	Proper quantity	Proper quantity	Proper quantity
pH after sterilization	6.4~ 6.6	6.9~ 7.1	7.9~ 8.1	6.4~ 6.6	7.9~ 8.1	6.4~ 6.6	7.9~ 8.1	7.2~ 7.4	7.2~ 7.4	6.4~ 6.6	6.9~ 7.1	7.2~ 7.4	7.9~ 8.1	5.9~ 6.1	5.9~ 6.1	7.9~ 8.1	5.9~ 6.1	6.4~ 6.6	5.9~ 6.1

Buffer solution:

Buffer solution is used in sterilized having composition and pH listed below.

Buffer No.1 (pH 4.5):

Dissolve by adding about 750 mL of water into 13.61 g (13.605~13.614 g) of potassium dihydrogen phosphate. If necessary, create 1,000 mL by adding more water after adjusting pH to be 4.4~4.6 by using potassium hydroxide test solution.

Buffer No. 2 (pH 6.0):

Dissolve by adding about 750 mL of water into 3.5 g (3.45~3.54 g) of potassium dihydrogen phosphate and 3.0 g (2.95~3.04 g) of sodium hydrogen phosphate dodecahydrate. If necessary, create 1,000 mL by adding more water after adjusting pH to be 5.9~6.1 by using 1 mol/L sodium hydroxide test solution or phosphoric acid (1 → 15).

Buffer No. 3 (pH 6.0):

Dissolve by adding about 750 mL of water into 7.0 g (6.95~7.04 g) of potassium dihydrogen phosphate and 6.0 g (5.95~6.04 g) of sodium hydrogen phosphate dodecahydrate. If necessary, create 1,000 mL by adding more water after adjusting pH to be 5.9~6.1 by using 1 mol/L sodium hydroxide test solution or phosphoric acid (1 → 15).

Buffer No. 4 (pH 8.0):

Dissolve by adding about 750 mL of water into 16.73 g (16.725~16.734 g) of potassium hydrogen phosphate and 0.523 g (0.5225~0.5234 g) of potassium dihydrogen phosphate, or 13.2 g (13.15~13.24 g) of Anhydrous sodium hydrogen phosphate and 0.91 g (0.905~0.914 g) of potassium dihydrogen phosphate. If necessary, create 1,000 mL by adding more water after adjusting pH to be 7.9~8.1 by using phosphoric acid.

Buffer No. 5 (pH 6.0):

Dissolve by adding about 750 mL of water into 80 g (79.5~80.4 g) of potassium dihydrogen phosphate and 20 g (19.5~20.4 g) of potassium hydrogen phosphate. If necessary, create 1,000 mL by adding more water after adjusting pH to be 5.9~6.1 by using potassium hydroxide solution (1 → 10).

Buffer No. 6 (pH 8.0):

Dissolve by adding about 750 mL of water into 13.3 g (13.25~13.34 g) of potassium dihydrogen phosphate and 100 g (99.5~100.4 g) of sodium chloride, and add 92 mL of potassium hydroxide test solution. If necessary, create 1,000 mL by adding more water after adjusting pH to be 7.9~8.1 by using potassium hydroxide test solution.

Buffer No. 7 (pH 7.0):

Dissolve by adding about 900 mL of water into 6.4 g (6.35~6.44 g) of potassium dihydrogen phosphate and 18.9 g (18.85~18.94 g) of sodium hydrogen phosphate dodecahydrate. If necessary, create 1,000 mL adding more water after adjusting pH to be 6.9~7.1 by using potassium hydroxide test solution or phosphoric acid.

Buffer No.8 (pH 4.0):

Dissolve by adding about 900 mL of water into 9.01 g (9.005~9.014 g) of lactic acid, and add 50 mL of 1 mol/L sodium hydroxide test solution. If necessary, create 1,000 mL by adding more water after adjusting pH to be 3.9~4.1 by using 1 mol/L sodium hydroxide test solution or phosphoric acid

Buffer No. 9 (pH 7.5):

Adjust pH to be 7.4~7.6 by adding 1 mol/L sodium hydroxide test solution into the buffer No. 2.

Standard and working standard:

Standard product as standard for determining a potency of working standard, and working standard as a standard for determining a potency of antibacterial substances, are antibacterial substance of specific serial numbers determined by the Food and Agricultural Materials Inspection Center.

Standard products and working standards are as follows. There are additional notes as references such as nature of itself.

Names of Standard Products	Nature of Standards	Names of Working Standards	Nature of Working Standards
Standard Avilamycin	Avilamycin A (C ₆₁ H ₈₈ Cl ₂ O ₃₂)	Working Standard Avilamycin	Avilamycin
Standard Enramaycin	Monohydrochloride enramaycin [monohydrochloride enramaycin A: C ₁₀₇ H ₁₃₈ Cl ₂ N ₂₆ O ₃₁ · HCl (58 %), Monohydrochloride enramaycin B: C ₁₀₈ H ₁₄₀ Cl ₂ N ₂₆ O ₃₁ · HCl (42 %)]	Working Standard Enramaycin	Monohydrochloride Enramaycin
Standard Salinomycin	Salinomycin Sodium (C ₄₂ H ₆₉ O ₁₁ Na)	Working Standard Salinomycin	Salinomycin Sodium
Standard Semduramicin	Semduramicin Sodium (C ₄₅ H ₇₅ O ₁₆ Na)	Working Standard Semduramicin	Semduramicin Sodium
Standard Narasin	Narasin A (C ₄₃ H ₇₂ O ₁₁)	Working Standard Narasin	Narasin A
Standard Nosiheptide	Nosiheptide (C ₅₁ H ₄₃ O ₁₂ N ₁₃ S ₆)	Working Standard Nosiheptide	Nosiheptide
Standard Bacitracin	Bacitracin (C ₆₆ H ₁₀₃ N ₁₇ O ₁₆ S)	Working Standard Bacitracin	Bacitracin
Standard Bicozamycin	Bicozamycin (C ₁₂ H ₁₈ N ₂ O ₇)	Working Standard Bicozamycin	Bicozamycin
Standard Flavophosphlipol	Flavophosphlipol (C ₆₅₋₇₅ H ₁₂₄₋₁₃₅ N ₆₋₇ O ₄₀₋₄₂ P)	Working Standard Flavophosphlipol	Flavophosphlipol
Standard Monensin	Monensin Sodium (Monensin A Sodium: C ₃₆ H ₆₁ O ₁₁ Na)	Working Standard Monensin	Monensin Sodium
Standard Lasalocid	Lasalocid Sodium (C ₃₄ H ₅₃ O ₈ Na)	Working Standard Lasalocid	Lasalocid Sodium

Definition of each antibacterial substance:

A. Avilamycin

It refers to same substance of this found by other method or others as a main component of avilamycin A (C₆₁H₈₈Cl₂O₃₂) and avilamycin B (C₅₉H₈₄Cl₂O₃₂) obtained by culturing *Streptomyces viridochromogenes*.

B. Enramaycin

It refers to same substance of this found by other method or others as a main component of enramycin A ($C_{107}H_{138}Cl_2N_{26}O_{31}$) and enramycin B ($C_{107}H_{140}Cl_2N_{26}O_{31}$) obtained by culturing *streptomyces fungicidicus*.

C. Salinomycin

It refers to same substance of this found by other method or salinomycin ($C_{42}H_{70}O_{11}$) obtained by culturing *streptomyces albus*.

D. Semduramicin

It refers to same substance of this found by other method or semduramicin ($C_{45}H_{76}O_{16}$) obtained by culturing *actinomadura roseorufa*.

E. Narasin

It refers to same substance of this found by other method or others as a main component of narasin A ($C_{43}H_{72}O_{11}$) obtained by culturing *streptomyces aureofaciens*.

F. Nosiheptide

It refers to same substance of this found by other method or nosiheptide ($C_{51}H_{43}O_{12}N_{13}S_6$) obtained by culturing *streptomyces actuosus*.

G. Bacitracin

It refers to same substance of this found by other method or others as a main component of bacitracin A ($C_{66}H_{103}N_{17}O_{16}S$) obtained by culturing *bacillus subtilis var. Tracy*.

H. Bicozamycin

It refers to same substance of this found by other method or bicozamycin ($C_{12}H_{18}N_2O_7$) obtained by culturing *streptomyces griseoflavus*.

I. Flavophosphlipol

It refers to same substance of this found by other method or flavophosphlipol ($C_{65-75}H_{124-135}N_{6-7}O_{40-42}P$) obtained by culturing *streptomyces bambergiensis*.

J. Monensin

It refers to same substance of this found by other method or others as a main component of monensin A ($C_{36}H_{62}O_{11}$) obtained by culturing *streptomyces cinnamomensis*.

K. Lasalocid

It refers to same substance of this found by other method or lasalocid ($C_{34}H_{54}O_8$) obtained by culturing *streptomyces lasaliensis*.

Definition of titer of each antibacterial substance:

A. Avilamycin

Titer of avilamycin indicates the amount of avilamycin A ($C_{61}H_{88}Cl_2O_{32}$) as mass (titer). 1 μ g (titer) is equivalent to 1 μ g of standard Avilamycin.

B. Enramycin

Titer of enramycin indicates the amount of monohydrochloride enramycin [monohydrochloride enramycin A ($C_{107}H_{138}Cl_2N_{26}O_{31} \cdot HCl$) 58 %, and monohydrochloride enramycin B ($C_{108}H_{140}Cl_2N_{26}O_{31} \cdot HCl$) 42 %] as mass (titer). The 1 μg (titer), under the reduced pressure of 0.13 kPa or less, is equivalent to 1 μg of standard enramycin dried for 4 hours at 60 °C.

C. Salinomycin

Titer of salinomycin indicates the amount of salinomycin sodium ($C_{42}H_{69}O_{11}Na$) as mass (titer). 1 μg (titer), under the reduced pressure of 0.67 kPa or less, is equivalent to 1 μg of standard salinomycin dried for 3 hours at 60 °C.

D. Semduramicin

Titer of semduramicin indicates the amount of semduramicin sodium ($C_{45}H_{75}O_{16}Na$) as mass (titer). 1 μg (titer), under the reduced pressure of 0.67 kPa or less, is equivalent to 1 μg of standard semduramicin dried for 3 hours at 100 °C.

E. Narasin

Titer of narasin indicates the amount of narasin A ($C_{43}H_{72}O_{11}$) as mass (titer). 1 μg (titer) is equivalent to 1 μg of standard narasin.

F. Nosiheptide

Titer of nosiheptide indicates the amount of nosiheptide ($C_{51}H_{43}O_{12}N_{13}S_6$) as mass (titer). 1 μg (titer) is equivalent to 1 μg of standard nosiheptide.

G. Bacitracin

Titer of bacitracin indicates the amount of bacitracin A ($C_{66}H_{103}N_{17}O_{16}S$) as unit. 1 unit, under the reduced pressure of 0.67 kPa or less, is equivalent to 23.8 μg of standard bacitracin dried for 3 hours at 60 °C.

H. Bicozamycin

Titer of bicozamycin indicates the amount of bicozamycin ($C_{12}H_{18}N_2O_7$) as mass (titer). 1 μg (titer) is equivalent to 1 μg of standard bicozamycin.

I. Flavophosphlipol

Titer of flavophosphlipol indicates the amount of flavophosphlipol ($C_{65-75}H_{124-135}N_{6-7}O_{40-42}P$) as mass (titer). 1 μg (titer) is equivalent to 1 μg of standard flavophosphlipol.

J. Monensin

Titer of monensin indicates the amount of monensin A ($C_{36}H_{62}O_{11}$) as mass (titer). 1 μg (titer) is equivalent to 1.064 μg of standard monensin.

K. Lasalocid

Titer of lasalocid indicates the amount of lasalocid sodium ($C_{34}H_{53}O_8Na$) as mass (titer). 1 μg (titer) is equivalent to 1 μg of standard lasalocid.

Preparation of bacterial solution or spore solution:

When using *Micrococcus luteus* ATCC 9341, *Micrococcus luteus* ATCC 10240, *Escherichia coli* ATCC 27166, *Bordetella bronchiseptica* ATCC 4617, *Corynebacterium xerosis* NCTC 9755, *Bacillus subtilis* ATCC 6633, *Bacillus brevis* ATCC 8185 or *Bacillus cereus* ATCC 19637 as test bacteria, except otherwise specified, bacterial solution or spore solution is prepared by the following method.

A. Preparation for the spore solution of *Micrococcus luteus* ATCC 9341, *Micrococcus luteus* ATCC 10240, *Escherichia coli* ATCC 27166, or *Bordetella bronchiseptica* ATCC 4617.

Transplant repeatedly approximately one week interval to the medium No. 18, and inoculate the test bacteria passaged to save while culturing at 32~37 °C into the medium No. 2 for use, and culture for 16 to 24 hours at 32~37 °C. Then, prepare the bacterial solution. Or, after inoculating the test bacteria passaged to save into a test tube slant agar medium (16 mm inner diameter) that contains 9 mL of the medium No. 18, culture for 16~24 hours at 32~37 °C, add 10 mL of saline to the test tube slant agar medium, and wash off the bacteria grown to transfer to other tube. Then the bacterial solution is prepared. Store the bacterial solution under 5 °C, and use *Micrococcus luteus* ATCC 9341 within 5 days and other bacteria within 7 days.

B. Preparation for bacteria solution of *Corynebacterium xerosis* NCTC 9755

Perform to passage to save for 16 to 24 hours three times at 35~37 °C at the medium No. 1. Transfer this to the medium No. 2, and culture them by shaking for 3~4 hours at 35~37 °C (Amplitude 5 cm and the vibration number 110 cycles/minute). Then bacteria solution is prepared. The bacterial solution is prepared at the time of use.

C. Preparation for spore solution of *Bacillus subtilis* ATCC 6633 and *Bacillus brevis* ATCC 8185

Transplant repeatedly in approximately three month interval to the medium No. 1, inoculate the test bacteria passaged to save while culturing at 32~37 °C into the same medium contained in a roux bottle, and culture them for one week at 32~37 °C. Then, the spore solution is prepared. Float in 100 mL of saline solution, and heat for 30 minutes at 65 °C. Perform performing centrifugation, take the spores, and further, after washing off by performing centrifugation three times with approximately 50 mL of the saline solution, float them in 100 mL of the saline solution, and heat for 30 minute at 65 °C. Then the spore solution is prepared. Store them under 5 °C, and use within 6 months.

D. Preparation for spore solution of *Bacillus cereus* ATCC 19637

Transplant repeatedly in approximately two weeks interval to the medium No. 1, inoculate the test bacteria passaged to save while culturing at 27~29 °C into the same medium contained in a roux bottle, and culture them for a week at 27~29 °C, and then, leave for about a week at room temperature (about 25 °C). Float the spores in 100 mL of the saline solution,

and heat for 30 minutes at 65 °C. Perform centrifugation, take the spores, further, after washing off by performing centrifugation three times with approximately 50 mL of the saline solution, float them in 100 mL of the saline solution, and heat for 30 minute at 65 °C. Then spores solution is prepared. Store them under 5 °C, and use within 6 months.

Preparation of cylindrical agar plates to stand:

Except otherwise specified, dispense 20 mL of base medium in the case of using Petri dish of about 90 mm inner diameter, and 21 mL of base medium in the case of using Petri dish of about 100 mm inner diameter, and 2~3 mm thickness of base medium in the case of using a large dish, spread them to be flat, and set on standing horizontally. Then, the base layer is created. Dissolve once, and add bacteria solution or spore solution at seed layer medium, as specified in the monographs, being cooled to temperature that does not inhibit the vitality of the test bacteria. After they are mixed well, dispense 4 mL of this in a Petri dish, and 1.5~2.5 mm thickness of base layer being packed in large dish, and spread them evenly on the upper surface of the base layer to set the medium on standing horizontally. Then, flat plate is created. Place each four cylinders (cup) to fit to be about 90° relative to the center on the flat plate (In the case of the Petri dish of about 90 mm inner diameter, on a circumference of about 25 mm radius, and in the case of the Petri dish of about 100 mm inner diameter, on a circumference of about 28 mm radius), and cylindrical agar plate is created. Also, when using a large flat dish, place the cylinder (cup) arranged to be equivalent to the petri dish flat plate, and set four as one petri dish. When placing the cylinder (cup) on the flat plate, drop the cylinder (cup) vertically from a height of 10~13 mm. Prepare the amount of bacterial solution or spore solution added to the seed layer medium so that the diameter of the inhibitory zone becomes 20~25 mm of by conventional standard dilutions of high concentration and the diameter of the inhibitory zone becomes 15~20 mm of by conventional standard dilutions of low concentration. It should be noted that instead of the cylindrical agar plates, it is possible to use perforation plates subjected to round perforations having with 7.9~8.1 mm diameter reaching the flat bottom unit to the plate.

Preparation of working standard dilution:

The working standard dilutions is liquid that appropriate amount of working is weighted in accordance with the monographs, and that is diluted to a specific concentration of two types of high and low when using the diluted stock solution being prepared. (Hereinafter indicate diluted solution of high concentration as “S_H”, and diluted solution of low concentration as “S_L”) When weighing working standard, except otherwise specified, weigh in air of 50 percent relative humidity, and weighted amount by chemical balance, they are listed in the Colum of working standards weighed amount in the following table. In the case where the drying conditions are listed in the column of working standards pre-drying condition in the same table, dry them beforehand in the conditions, and weigh the specified amount. Further, the dilute stock solution

need to be stored at temperature listed in the column of dilution stock solution storage temperature in the following table, and the working standard dilution is prepared at the time of use.

Working Standard Name	Working Standards Weighed Amount	Working Standards Pre-drying Condition	Dilution Stock Solution Storage Temperature	Dilution Stock Solution Validity Period
Working Standard Avilamycin	About 20mg (titer) equivalent amount or more	2.67~3.33 kPa, 60 °C, 3 hours	5 °C or less	30 days
Working Standard Enramycin	About 20mg or more	0.27 kPa or less, 60 °C, 3 hours	5 °C or less	7 days
Working Standard Salinomycin	About 20mg (titer) equivalent amount or more	0.67 kPa or less, 60 °C, 3 hours	5 °C or less	14 days
Working Standard Semduramicin	About 25mg (titer) equivalent amount or more	0.67 kPa or less, 100 °C, 3 hours	5 °C or less	7 days
Working Standard Narasin	About 25mg (titer) equivalent amount or more	—	5 °C or less	14 days
Working Standard Nosiheptide	About 20mg or more	—	5 °C or less	14 days
Working Standard Bacitracin	About 30mg or more	0.67 kPa or less, 60 °C, 3 hours	5 °C or less	2 days
Working Standard Bicozamycin	About 20mg or more	0.67kPa or less, 60 °C, 3 hours	5 °C or less	4 days
Working Standard Flavophosphlipol	About 2mg or more	—	10 °C or less	14 days
Working Standard Monensin	About 20mg (titer) equivalent amount or more	—	5 °C or less	14 days
Working Standard Lasalocid	About 20mg or more	—	5 °C or less	30 days

Preparation of the sample solution:

It is specified in the monographs. (Hereinafter indicate sample solution of high concentration as “U_H”, and sample solution of low concentration “U_L”) The sample stock solution or the sample solution for the test must not be used after the next day of the preparation.

Procedure:

Five cylinder agar plates (In the case of using the large dish cylinder agar plate, placement division equivalent to this) are used. As the cylinder agar plate is shown in the following figure, fill S_H in the first cylinder, U_H in the second cylinder, S_L in the third cylinder, and U_L in the fourth cylinder, then culture *Bacillus cereus* at 27~29 °C and other bacteria at 32~37 °C for 16~20 hours by placing them in the incubator with caution. After culturing, measure the diameter of each inhibition zone with at least an accuracy of 0.25 mm.

If necessary, fill out the diameter of the inhibition zones being measured in a card style shown in the following table. The working standard dilution and the sample solution injected into the holes of the perforated plate agar are filled with a certain amount each time.

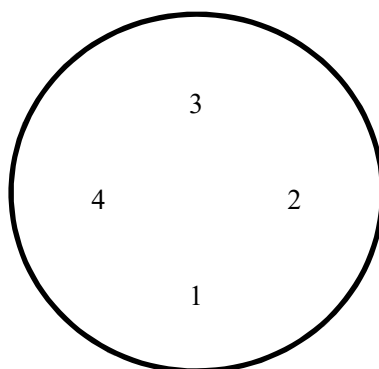

Cylinder Number	1	3	2	4
Agar Plate / Cylinder Contents	Common Standard Dilution for High Concentration S _H	Common Standard Dilution for Low Concentration S _L	High Concentration Sample Solution U _H	Low Concentration Sample Solution U _L
I	mm	mm	mm	mm
II				
III				
IV				
V				
Total	ΣS _H	ΣS _L	ΣU _H	ΣU _L

Titer calculation:

Between the titer of the liquid in the cylinder (P) and the diameter of inhibition zone (d), the following relationship is established.

$$d = \alpha \log P + \beta \quad (\alpha \text{ and } \beta \text{ are constants})$$

If necessary, confirm this equation, and calculate the titer from a sample taken by the following equation.

Titer of sample collected = A × titer in 1 mL of high concentration working standard dilution × dilution ratio of high concentration sample solution.

However,

$$\log A = \frac{I \times V}{W}$$

$$I = \log \frac{S_H \text{ titer}}{S_L \text{ titer}}$$

$$V = \Sigma U_H + \Sigma U_L - \Sigma S_H - \Sigma S_L$$

$$W = \Sigma U_H + \Sigma S_H - \Sigma U_L - \Sigma S_L$$

The sum (mm) of the inhibition zone diameter of each cylinder of S_H , S_L , U_H and U_L are indicated as ΣS_H , ΣS_L , ΣU_H , and ΣU_L .

(14) Enzymatic Activity Test Method**A. Xylan saccharification power test method**

Xylan saccharification power test method, when the xylanase acts on xylan, is a method for determining amount of xylanase in feed additive by reducing power to increase with hydrolysis, and the unit is indicated as the xylan saccharification power unit. One xylan saccharification power unit is equivalent to the amount of enzyme leads to an increase in the reducing power corresponding to 1 μmol of xylose in one minute of the initial stage of the reaction when xylanase acts at 40 °C in xylan.

Preparation of substrate solution:

Weigh 4.0 g (3.95~4.04 g) of xylan, dissolve by shaking vigorously while slowly adding to 50 mL of 1 mol/L sodium hydroxide test solution, add 2 drops of phenolphthalein test solution, and neutralized with 1 mol/L hydrochloric acid test solution. Then, add a 100 mL of 0.1 mol/L acetate-sodium acetate buffer adjusted to pH showing the maximum activity of the sample, and place them in a volumetric flask of 200 mL. 200 mL is created by adding water to the marked line.

Procedure:

Weigh up to 3 significant digits of amount of the sample required to perform the test, record the number, and dissolve by adding 0.01 mol/L acetate-sodium acetate buffer adjusted to pH showing

the maximum enzymatic activity of the sample or water so that the concentration per 1 mL becomes 0.1~0.2 xylan saccharification power unit. Then, use this solution as the sample solution. When the sample is not completely melted, leave for 1 hour by stirring occasionally, centrifuged, and use the supernatant as the sample solution. Weigh 2 mL of the substrate solution by using a transfer pipette, place in a test tube of 25 × 200 mm, and leave for 5 minutes in a water bath at 40 ± 0.2 °C, then, add 1 mL the sample solution of by using a transfer pipette and shake well, and leave for exactly 30 minutes in a water bath at 40 ± 0.2 °C within 30 seconds.

Next, add 0.5 mL of sulfuric acid (6 → 100), shake well and leave for 10 minutes, add 1 drop of phenolphthalein test solution, and neutralize with 1 mol/L sodium hydroxide test solution. Then, after creating 5 mL by adding water, add 5 mL of alkaline copper test solution A by using the transfer pipette, cover lightly the mouth of the test tube with aluminum foil, and cool them to 20~30 °C after heating in a water bath for 20 minutes while shaking occasionally. After cooling, add 2 mL of potassium (1 → 40), further, add 1.5 mL of sulfuric acid (6 → 100), and shake vigorously for 30 seconds. After the solution became clear, titrate with 0.005 mol/L sodium thiosulfate solution (indicator, 1 mL of starch test solution). In this case, the end point of the titration is the time when the blue color disappears, and the titer is A mL.

Separately, weigh 2 mL of substrate solution by using the transfer pipette, place in a test tube of 25 × 200 mm, and add 0.5 mL of sulfuric acid (6 → 100). After shaking well, add 1 mL of sample solution by using the transfer pipette, shake well. Next, add 1 drop of phenolphthalein test solution, and operate according to the same method as the following, and the titer is indicated as B mL. Obtain the amount (g) of xylose corresponding a difference (B - A) (mL) in the consumption of 0.005 mol/L sodium thiosulfate solution from a calibration curve, and indicate as K.

$$\text{Xylan saccharification power unit in 1 g} = \frac{K}{150.13 \times 10^{-6} \times 30} \times \frac{1}{W}$$

W: The amount of sample in 1 mL of sample solution (g)

Creating a calibration curve:

Dry xylose for 3 hours at 105 °C, and weigh 0.50 g (0.495~0.504 g), place in a volumetric flask of 100 mL, dissolve by adding water, and create 100 mL by adding more water to the marked line. Weigh 1 mL, 2 mL, 3 mL, and 4 mL of this solution by using a transfer pipette, place each in volumetric flask of 100 mL, and create 100 mL by adding water to the marked line for each. Weigh 5 mL of each solution by using the transfer pipette, place in each test tube of 25 × 200 mm, add alkaline copper test solution A 5 mL by using the transfer pipette, operate in a manner similar to the sample below, indicate the titer as S₁ mL, S₂ mL, S₃ mL, and S₄. Separately, weigh 5 mL of water by using the transfer pipette, place in a test tube of 25 × 200 mm, add alkaline copper test solution A 5 mL by using the transfer pipette, operate in a manner similar to the sample below, and indicate the titer as B' mL. Take the difference (B' - S₁), (B' - S₂), (B' - S₃) and (B' - S₄) in

consumption of 0.005 mol/L sodium thiosulfate solution to vertical axis, and the amount of xylose (g) corresponding to each to horizontal axis, and create a calibration curve.

B. β -glucan saccharification power test method

β -glucan saccharification power test method is a method by measuring the amount of β -glucanase in feed additive by reducing power to increase with the hydrolysis when the β -glucanase acts on β -glucan, and the unit is indicated as β -glucan saccharification power unit.

When the β -glucanase acts on β -glucan at 30 °C, 1 β -glucan saccharification power unit corresponds to the amount of enzyme leading to an increase in the reducing power corresponding to 1 μ mol of glucose of in one minute of the initial stage of the reaction.

Preparation of substrate solution:

Weigh 1.0 g (0.95~1.04 g) of β -glucan, place in a volumetric flask of 100 mL, moisten with 10 mL of ethanol, add 80 mL of water, and boil and dissolve the β -glucan. Return to room temperature with stirring, create 100 mL by adding water to the marked line of the volumetric flask, and filter through a glass filter (G3). Use within two days by storing in the refrigerator.

Procedure:

Weigh up to three significant digits of the amount of sample required to perform the test, record the number, dissolve by adding 0.1 mol/L acetate-sodium acetate buffer adjusted to pH showing a maximum enzyme activity of the sample so that the concentration of per 1 mL becomes 0.1~0.2 β -glucan saccharification power unit. Then, use this solution as the sample solution. If the sample is not completely melted, mix and stir for 1 hour, centrifuge, and use the supernatant as the sample solution. Weigh 1 mL of substrate solution by using a transfer pipette, place in a test tube of 16 × 200 mm, leave for 5 minutes in a water bath at 30 ± 0.2 °C, add 1 mL of the sample solution by using the transfer pipette and shake well, and leave for exactly 10 minutes in a water bath at 30 ± 0.2 °C within 30 seconds. Next, add 3 mL of dinitrosalicylic acid test solution by using the transfer pipette and shake well, cover the mouth of the tube lightly with aluminum foil, boil for exactly 5 minutes, cool in a cold water bath, and return to room temperature. For this solution, measure the absorbance A_T at 540 nm of wavelength. Separately, weigh 1 mL of substrate solution by using the transfer pipette, place in a test tube of 16 × 200 mm, add 3 mL of dinitrosalicylic acid test solution by using the transfer pipette and shake well, add 1 mL of the sample solution by using the transfer pipette and shake well, and leave for exactly 10 minutes in a water bath at 30 ± 0.2 °C within 30 seconds. By operating in the same manner below, measure the absorbance A_T' .

$$\beta\text{-glucan saccharification power unit in 1 g} = \frac{A_T - A_T'}{10 \times 0.18} \times \frac{1}{W} \times F$$

W: The amount of the sample in 1 mL of the sample solution (g)

F: The amount of glucose to the absorbance difference 1 obtained from the calibration curve (mg)

Creating a calibration curve:

Weigh up to digit 0.01 g of about 1 g of glucose in advance, record the number, dry for 6 hours at 105 °C, and measure the weight loss. Weigh up digit 0.01 g of glucose corresponding to 1 g of the dried product, dissolve by adding water, place in a volumetric flask of 100 mL, and create 100 mL by adding more water to the marked line.

Weigh 1 mL, 2 mL, 3 mL, 4 mL, 5 mL and 6 mL of the solution by using the transfer pipette, place each in a volumetric flask of 100 mL, and create 100 mL each by adding water to the marked line. Weigh 1 mL of each solution and 1 mL of water by using the transfer pipette, place in a test tube of 16 × 200 mm, add 3 mL each of dinitrosalicylic acid test solution by using the transfer pipette and shake well, cover the mouth of the test tube lightly with aluminum foil, boil for exactly 5 minutes, cool in a cold water bath, and return to room temperature.

For these solutions, measure A_1 , A_2 , A_3 , A_4 , A_5 , and A_6 of the absorbance at wavelength of 540 nm. Separately, weigh 2 mL of water by using the transfer pipette, place in a test tube of 16 × 200 mm, add 3 mL of dinitrosalicylic acid test solution by using the transfer pipette, and measure the absorbance A_0 by operating in the same manner below. Take the absorbance difference, $(A_1 - A_0)$, $(A_2 - A_0)$, $(A_3 - A_0)$, $(A_4 - A_0)$, $(A_5 - A_0)$ and $(A_6 - A_0)$ to vertical axis, and the amount of glucose (mg) to horizontal axis, and create a calibration curve.

C. Fat digestion test method

Fat digestion test method is a method by measuring the amount of lipase in feed additives depending on the amount of fatty acids increasing with the hydrolysis when lipase acts on olive oil, and the unit is indicated as fat digestion unit. When lipase acts on the olive oil, 1 fat digestion unit corresponds to the amount of enzyme resulting in an increase of digestion corresponding to 1 μmol of fatty acids in one minute of the initial stage of the reaction.

Preparation of substrate solution:

Weigh 200~300 mL of polyvinyl alcohol test solution and olive oil mixture (3:1), place in a 500 mL container of emulsifier, emulsify for 10 minutes at 12,000 to 16,000 revolutions per minute while cooling to 10 °C or less, leave for 1 hour in the cold place, and use after it is confirmed that the oil layer is not separated.

Procedure:

Weigh up to three significant digits of the amount of sample required to perform the test and record the number, dissolve by adding of cold water so that concentration of per 1 mL becomes 1.0 to 5.0 fatty digestion units, and use this solution as the sample solution. If necessary, perform centrifugation or filtration. Weigh 4 mL of 0.1 mol/L phosphate buffer adjusted to pH showing the maximum enzymatic activity of 5 mL of the substrate solution and the sample by using the

transfer pipette, mix well and leave for 10 min at 37 ± 0.5 °C, add 1 mL of the sample solution by using the transfer pipette, shake within 30 seconds, and leave for exactly 20 minutes at 37 ± 0.5 °C. Next, add 10 mL of acetone and ethanol mixed solution (1:1) and shake, add 10 mL of 0.05 mol/L sodium hydroxide test solution by using the transfer pipette, further, add 10 mL of the acetone and ethanol mixed solution (1:1) by using the transfer pipette and shake, and titrate with 0.05 mol/L hydrochloric acid. (Indicator reagent, 2~3 drops of phenolphthalein test solution)

In this case, the end point of the titration is the time when the red color disappears, and the titer is A mL. Separately, weigh 4 mL of 0.1 mol/L phosphate buffer adjusted to pH showing the maximum enzymatic activity of 5 mL of the substrate solution and the sample by using the transfer pipette and mix well, and leave for 30 minutes at 37 ± 0.5 °C. Then, add 10 mL of the acetone and ethanol mixed solution (1:1) by using the transfer pipette and shake, and further, add 1 mL of the sample solution by using the transfer pipette and shake, and operate in the same manner below. The titer is B mL.

$$\text{Fat digestion unit in 1 g} = 50 \times (B - A) \times \frac{1}{20} \times \frac{1}{W}$$

W: The amount of sample in 1 mL of the sample solution (g)

D. Fiber saccharification power test method

Fiber saccharification power test method is a method to determine the amount of cellulase in feed additive when the cellulase acts on carboxymethyl cellulose sodium, and the unit is indicated as fibers saccharification power unit. When the cellulase acts on carboxymethylcellulose sodium at 37 °C, 1 fiber saccharification power unit corresponds to the amount of enzyme leading to an increase in the reducing power corresponding to glucose of 1 μmol in one minute of the initial stage of the reaction.

Preparation of substrate solution:

Weigh up to digit 0.001 g of about 1 g of carboxymethyl cellulose sodium in advance, record the number and dry for 4 hours at 105 °C, and measure the weight loss. Weigh up to digit 0.001 g of the carboxymethyl cellulose sodium corresponding to 0.625 g of the dried product, add the small portion with stirring in 50 mL of water, dissolve by heating for 20 minutes while stirring occasionally at 60~70 °C, allow to cool and transfer to a volumetric flask of 100 mL, and add 10 mL of 1 mol/L acetate-sodium acetate buffer adjusted to pH showing the maximum enzymatic activity of the sample, then, 100 mL is created by adding more water to the mark.

Procedure:

Weigh up to three significant digits of the amount of sample required to perform the test, record the number, and dissolve by adding 0.1 mol/L acetate-sodium acetate buffer adjusted to pH showing the maximum enzymatic activity of the sample or water so that the concentration of per 1 mL becomes 0.02~0.08 fibers diastatic power unit. Then, use this solution as the sample solution.

If this is not completely melted, leave for 1 hour while stirring occasionally, centrifuge, and use the supernatant as the sample solution. Weigh 4 mL of substrate solution by using the transfer pipette, place in a volumetric flask of 25 mL, leave for 10 minutes at 37 ± 0.5 °C, add 1 mL of a sample solution by using a transfer pipette, shake within 30 seconds, and leave for exactly 30 minutes at 37 ± 0.5 °C.

Next, add 2 mL of alkaline copper test solution B and shake, place a stopper on a volumetric flask, heat for 30 minutes in a water bath, and cool the water. Further, add 2 mL of arsenic molybdate test solution, shake well, add 3 mL of 0.5 mol/L sodium hydroxide test solution, dissolve the precipitate by shaking, and leave for 20 minutes. In addition, add 1 mol/L acetic acid-sodium acetate buffer solution adjusted to pH showing the maximum enzymatic activity of the sample to the marked line and then create 25mL. Weigh 1 mL of this solution by using the transfer pipette, add 9 mL of 1 mol/L acetate-sodium acetate buffer adjusted to pH showing the maximum enzymatic activity of the sample and shake well, and measure absorbance A_T at wavelength of 750 nm. Separately, weigh 1 mL of sample solution by using the transfer pipette, place in a volumetric flask of 25 mL, add 2 mL of alkaline copper test solution B and shake, add 4 mL of substrate solution by using the transfer pipette and shake, place a stopper on a volumetric flask, and heat for 30 minutes in a water bath, then, cool the water. Operate in the same manner below, and measure the absorbance $A_{T'}$. Obtain the amount of glucose (mg) corresponding to A_T and $A_{T'}$ from the calibration curve, and indicate as G_T and $G_{T'}$.

$$\text{Fiber saccharification power unit in 1g} = \frac{G_T - G_{T'}}{30} \times \frac{1}{0.18} \times \frac{1}{W}$$

W: The amount of sample in 1 mL of the sample solution (g)

Creating a calibration curve:

Weigh up to digit 0.01 g of 1 g of glucose in advance and record the number, dry for 6 hours at 105 °C, and measure the weight loss. Weigh up to digit 0.01 g of glucose corresponding to 1 g of the dried product, dissolve by adding water, place in a volumetric flask of 1,000 mL, and create 1,000 mL by adding more water to the marked line. Weigh 1 mL, 2 mL, 3 mL, 4 mL and 5 mL of this solution by using a transfer pipette, place in a volumetric flask of 10 mL, and create 10 mL each by adding water to the marked line. Weigh 1 mL of the solution each, 4 mL of substrate solution, and 2 mL of alkaline copper test solution B by using the transfer pipette, place in a volumetric flask of 25 mL and shake, and place a stopper on a volumetric flask, then heat for 30 minutes in a water bath. After cooling with water, add 2 mL of arsenic molybdate test solution and shake well, add 3 mL of 0.5 mol/L sodium hydroxide test solution, dissolve by shaking, leave for 20 minutes, and add 1 mol/L acetate-sodium acetate buffer adjusted to pH showing the maximum enzymatic activity of the sample to the marked line. Then, create 25 mL each. Weigh 1 mL of these solutions by using the transfer pipette, add 9 mL of 1 mol/L acetate-sodium acetate buffer

adjusted to pH showing the maximum enzymatic activity of the sample, and shake well. For these each solution, measure the absorbance of A₁, A₂, A₃, A₄ and A₅ at wavelength of 750 nm. Separately, weigh 1 mL of water, 4 mL of substrate solution and 2 mL of alkaline copper test solution B by using the transfer pipette, and operate according to the same method as follows. and measure the absorbance A₀. Take the absorbance difference (A₁ - A₀), (A₂ - A₀), (A₃ - A₀), (A₄ - A₀) to vertical axis, and take the amount of glucose (mg) to horizontal axis, and create a calibration curve.

E. Fiber disintegrating power test method

When cellulase acts on filter paper, by the time the filter paper to collapse, fiber disintegrating power test method is a method by measuring the amount of the cellulase in feed additives, and indicated as fiber disintegrating power unit. When the cellulase acts on the filter paper at 37 °C, 1,000 fiber disintegrating power units corresponds to the amount of enzyme which completely disintegrate the two pieces of filter paper for enzyme determination of the size of 1cm × 1cm per minute.

Preparation of the substrate:

Observe filter paper (paper thickness 0.29~0.31 mm, mass 125~135 g/m², α fiber content 98.5 % or more, ash content 0.05 % or less, filtering time 50~90 seconds/100 mL, burst strength 1.2~1.8 kg/cm², water absorption elevation 8~9cm/10 minutes, and air permeability 30~40 seconds /cm²/100 mL, are specified.) for enzyme determination through light source, and cut the parts where there are no foreign material having an even thickness to the size of 1cm × 1cm.

Procedure:

Weigh up to three significant digits of the amount of the sample required to perform the test, record the number, dissolve by adding 1 mol/L acetate-sodium acetate buffer adjusted to pH showing the maximum enzymatic activity of the sample so that the concentration per 1 mL becomes 2.8 to 4.0 fibers disintegrating force units. Then, use this solution as the sample solution. If this is not completely melted, leave for 1 hour and stirring occasionally, centrifuge, and use the supernatant as the sample solution. Weigh 5 mL each of the sample solution by using the transfer pipette, place in five of L-shaped test tubes, leave for 5 minutes at 37 ± 0.5 °C, place two pieces each of the substrates in each, and 65 rpm, amplitude 60 mm, and shake within 30 seconds at 37 ± 0.5 °C temperature. Observe the collapsed state of the filter paper in a timely manner. The filter paper is completely destroyed, and measure the time (in minutes) until fine fiber is created.

$$\text{Fiber disintegrating power unit in 1 g} = \frac{1}{T \times W} \times 1,000$$

T: Average of the time (except for the longest and shortest) until the filter paper is completely destroyed (minutes).

W: The amount of sample in 5 mL of the sample solution (g)

L-Shaped Test Tube

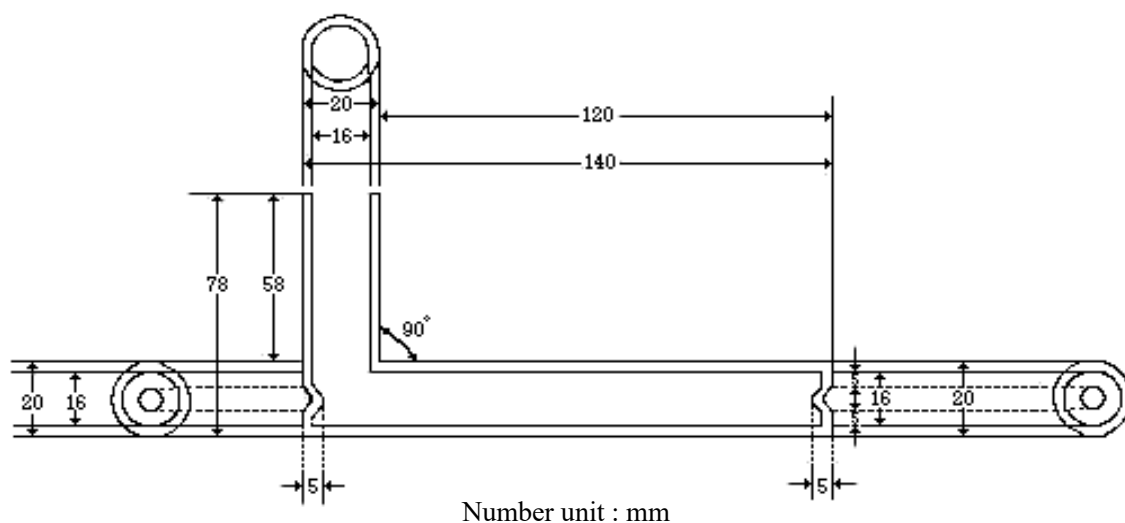

F. Protein digestion test method

Protein digestion test method is a method by measuring the amount of protease in feed additives by the amount of acid soluble degradation products increasing with the hydrolysis when the protease acts on casein. The unit is shown as protein digestion unit.

1 protein digestion unit is equivalent to the amount of enzyme leading to an increase in folin test solution color material of non-protein of which corresponds to $1\mu\text{g}$ of tyrosine per minute of the initial stage of the reaction when the protease acts on dairy casein at $37\text{ }^{\circ}\text{C}$.

(a) Method 1

Preparation of substrate solution:

Weigh up to digit 0.01 g of about 1 g of dairy casein in advance and record the number, dry for 2 hours at $105\text{ }^{\circ}\text{C}$, and measure the weight loss. Weigh up to digit 0.01 g of the dairy casein corresponding to 1.20 g of the dried product, add 160 mL of 0.05 mol/L sodium hydrogen phosphate test solution, and dissolve by heating in a water bath. After cooling this solution with running water, adjust to pH showing the maximum enzymatic activity of the sample by adding 1 mol/L sodium hydroxide test solution or 1 mol/L hydrochloric acid test solution, place in a volumetric flask of 200 mL, and 200 mL is created by adding water to the marked line.

Operation:

Weigh up to three significant digits of the amount of sample required to perform the test, record the number, dissolve by adding water or 0.02 mol/L phosphoric acid so that the concentration per 1 mL becomes 10 to 30 protein digestion units, and use this solution as the sample solution. If necessary, perform centrifugation or filtration. Weigh 5 mL of the substrate by using a transfer pipette, leave for 10 minutes at $37 \pm 0.5\text{ }^{\circ}\text{C}$, add 1 mL of the

sample solution by using the transfer pipette and shake within 30 seconds, and leave for 10 minutes at exactly 37 ± 0.5 °C. Then, add 5 mL of trichloroacetic acid test solution B and shake, and leave for 30 minutes at 37 ± 0.5 °C.

Further, after removing the precipitate completely by filtering this solution, weigh 2 mL of the filtrate by using the transfer pipette, add 5 mL of 0.55 mol/L sodium carbonate test solution and 1 mL (1 → 3) of folin test solution, shake well, and leave for 30 minutes at 37 ± 0.5 °C. And, for this solution, measure the absorbance A_T at wavelength of at 660nm. Separately, weigh 1 mL of sample solution by using a transfer pipette, add 5 mL of trichloroacetic acid test solution B and shake, add exactly 5 mL of substrate solution, and leave for 30 minutes at 37 ± 0.5 °C. By operating in the same manner below, measure the absorbance $A_{T'}$.

$$\text{Protein digestion unit in 1 g} = (A_T - A_{T'}) \times F \times \frac{11}{2} \times \frac{1}{10} \times \frac{1}{W}$$

F: The amount of tyrosine corresponding to absorbance difference 1 obtained from the calibration curve (μg)

W: The amount of sample in 1 mL of the sample solution (g)

Creating a calibration curve:

Dry tyrosine standard for 3 hours at 105 °C, weigh 0.500 g (0.4995~0.5004 g) of this, dissolve by adding 0.2 mol/L hydrochloric acid test solution, place in a volumetric flask of 500 mL, and add 0.2 mol/L hydrochloric acid reagent more to the marked line to create 500mL. Weigh 1 mL, 2 mL, 3 mL and 4 mL of this solution by using a transfer pipette, place each in volumetric flasks of 100 mL, and add 0.2 mol/L hydrochloric acid test solution to the marked line each to create 100mL. Weigh 2 mL each of the solution by using a transfer pipette solution, add 5 mL each of 0.55 mol/L sodium carbonate test solution and 1 mL (1 → 3) of folin test solution, leave for 30 minutes at 37 ± 0.5 °C, and for these solution, measure the absorbance A_1 , A_2 , A_3 and A_4 at wavelength of 660nm. Separately, weigh 2 mL of 0.2 mol/L hydrochloric acid test solution by using a transfer pipette, By operating in the same manner below, measure the absorbance A_0 . Take the absorbance difference ($A_1 - A_0$), ($A_2 - A_0$), ($A_3 - A_0$) and ($A_4 - A_0$) to vertical axis, and take the amount of tyrosine (μg) to horizontal axis, and create a calibration curve.

(b) Method 2

Preparation of substrate solution:

Weigh up to digit 0.01 g of 1 g of dairy casein in advance, record the number, dry for 2 hours at 105 °C, and measure the weight loss. Weigh up digit 0.01 g of dairy casein corresponding to 1.20 g of the dried products, add 16 mL of 1 mol/L lactic acid test solution and 146 mL of water, dissolve by warming in a water bath. After cooling with running water,

adjust this solution adjusted to pH showing the maximum enzymatic activity of the sample by addition of 1 mol/L sodium hydroxide test solution or 1 mol/L hydrochloric acid test solution, place in a volumetric flask of 200 mL, and create 200 mL by adding water to the marked line.

Procedure:

Weigh up to three significant digits of sample required to perform the test, record the number, dissolve by adding 0.1 mol/L lactate buffer, acetic acid/hydrochloric acid buffer, and 0.01 mol/L acetic acid-sodium acetate buffer so that the concentration per 1 mL becomes 10 to 30 protein digestion units. Then, use this solution as the sample solution. If necessary, perform centrifugation or filtration. Weigh 5 mL of substrate solution by using a transfer pipette, leave for 10 minutes at 37 ± 0.5 °C, add 1 mL of sample solution by using the transfer pipette, shake within 30 seconds, leave for 10 minutes at exactly 37 ± 0.5 °C. Next, add 5 mL of trichloroacetic acid test solution A and shake, and leave for 30 minutes at 37 ± 0.5 °C. Further, after removing the precipitate completely by filtering this solution, weigh 2 mL of the filtrate by using the transfer pipette, add 5 mL of 0.55 mol/L sodium carbonate test solution and 1 mL (1 → 3) of folin test solution and shake well, leave for 30 minutes at 37 ± 0.5 °C, and for this solution, measure the absorbance A_T at wavelength of 660nm. Separately, weigh 1 mL of sample solution by using the transfer pipette, add 5 mL of trichloroacetic acid test solution A and shake, add 5 mL of substrate solution by using the transfer pipette, and leave for 30 minutes at 37 ± 0.5 °C. Operate in the same manner below, and measure the absorbance A_T' .

$$\text{Protein digestion unit in 1 g} = (A_T - A_T') \times F \times \frac{11}{2} \times \frac{1}{10} \times \frac{1}{W}$$

F: The amount of tyrosine corresponding to absorbance difference 1 obtained from the calibration curve (μg)

W: The amount of sample in 1 mL of the sample solution (g)

Creating a calibration curve:

Apply mutatis mutandis to create the calibration curve of (a).

(c) Method 3

Preparation of substrate solution:

Apply mutatis mutandis to prepare the substrate solution of (a).

Operation:

Weigh up to three significant digits of the amount of sample required to perform the test, record the number, dissolve by adding of water so that 1 mL of the concentration per 1 mL becomes 10 to 30 protein digestion units, and use this solution as the sample solution. If necessary, perform centrifugation or filtration. Weigh 5 mL of substrate solution by using a

transfer pipette, and leave for 10 minutes at 37 ± 0.5 °C, add 1 mL of sample solution by using a transfer pipette, shake within 30 seconds, and leave for 10 minutes at exactly 37 ± 0.5 °C. Next, add 5 mL of trichloroacetic acid test solution A and shake, and leave for 30 minutes at 37 ± 0.5 °C. Further, after removing the precipitate completely by filtering this solution, weigh 2 mL of the filtrate by using a transfer pipette, add 5 mL of 0.55 mol/L sodium carbonate test solution and 1 mL (1 → 3) of folin test solution and shake well, leave for 30 minutes at 37 ± 0.5 °C, and for this solution, measure the absorbance A_T at wavelength of 660nm. Separately, weigh 1 mL of sample solution by using a transfer pipette, add 5 mL of trichloroacetic acid test solution A and shake, add 5 mL of the substrate solution by using a transfer pipette, and leave for 30 minutes at 37 ± 0.5 °C. Operate in the same manner below, and measure the absorbance $A_{T'}$.

$$\text{Protein digestion unit in 1 g} = (A_T - A_{T'}) \times F \times \frac{11}{2} \times \frac{1}{10} \times \frac{1}{W}$$

F: The amount of tyrosine corresponding to absorbance difference 1 obtained from the calibration curve (μg)

W: The amount of sample in 1 mL of the sample solution (g)

Creating a calibration curve:

Apply mutatis mutandis to create the calibration curve of (a).

G. Starch saccharification power test method

Starch saccharification power test method is a method to determine the amount of amylase in feed additive by reducing power to increase with the hydrolysis when amylase acts on starch, and the unit is indicated as starch saccharification power unit. When amylase acts on potato starch at 37 °C, 1 starch saccharification power unit corresponds to the amount of enzyme leading to an increase in the reducing power corresponding to 1 mg of glucose per minute of the initial stage of the reaction.

Preparation of substrate solution:

Weigh up to digit 0.01 g of about 1 g of potato starch in advance, record the number, dry for 2 hours at 105 °C, and measure the weight loss. Weigh up to digits 0.01 g of the potato starch corresponding to 1 g of the dried product, place in an Erlenmeyer flask, add 20 mL of water, make pasty form by gradually adding 5 mL of 2 mol/L sodium hydroxide test solution while shaking well, heat for 3 minutes in water bath while shaking, add 25 mL of water and leave to cool, and neutralize accurately with 2 mol/L hydrochloric acid test solution. Then, add 10 mL of 1 mol/L acetate-sodium acetate buffer adjusted to pH showing the maximum enzymatic activity of the sample and place in a volumetric flask of 100 mL, and create 100 mL by adding more water to the marked line.

Procedure:

Weight up to three significant of sample required to perform the test, record the number, and dissolve by adding 0.1 mol/L lactate buffer adjusted to pH showing the maximum enzymatic activity of sample or water so that the concentration per 1 mL becomes 0.4 to 0.8 of starch saccharine power units. Then, use this solution as the sample solution. If necessary, perform centrifugation or filtration. Weigh 10 mL of substrate solution by using a transfer pipette, place in a test tube of diameter of 30 mm, leave for 10 minutes at 37 ± 0.5 °C, add 1 mL of sample solution by using the transfer pipette, shake 30 within seconds, and leave for 10 minutes at exactly 37 ± 0.5 °C. Next, add 2 mL of alkaline titrate solution of fehling test solution, shake within 30 seconds, add 2 mL of copper solution of fehling test solution by using the transfer pipette and shake lightly, place the funnel into the mouth of the test tube, and heat for exactly 15 minutes in a water bath and cool to below 25 °C under running water within 30 seconds. In addition, add 2 mL of potassium iodide test solution (1 → 6) and 2 mL of sulfuric acid, and titrate the separated iodine with 0.05 mol/L sodium thiosulfate solution within 30 seconds (Indicator, 1-2 drops of soluble starch test solution). In this case, the end point of the titration is the time when the blue color disappears, and the titer is A mL. Separately, weigh 10 mL of water instead of substrate solution, operate in the same manner below, and the titer is B mL.

$$\text{Starch saccharification power unit in 1 g} = (B - A) \times 1.6 \times \frac{1}{10} \times \frac{1}{W}$$

W: The amount of sample in 1 mL of the sample solution (g)

H. Phytic acid decomposition power test method

Phytic acid decomposition power test is a method by measuring the amount of phytase in feed additive by the amount of phosphate ion produced by hydrolysis when phytase acts on phytic acid, and the unit is indicated by phytic acid decomposition power unit. When the phytase acts on phytic acid at 37 °C, phytic acid decomposition power unit corresponds to the amount of enzyme that separates 1 μmol of phosphoric acid in one minute of the initial stage of the reaction.

(a) Method 1**Preparation of substrate solution:**

Dry sodium phytate for at least 24 hours in a desiccator (silica gel) in advance, weigh 0.271 g (0.2705~0.2714 g), dissolve by adding 50 mL of 0.2 mol/L acetate-sodium acetate buffer solution adjusted to pH showing the maximum enzymatic activity of the sample, adjust to pH 5.5 by adding 0.2 mol/L acetic acid test solution, and place in a volumetric flask of 100 mL, then create 100 mL by adding the same buffer to the marked line.

Preparation of reaction stop coloring solution:

Dissolve 1.236 g (1.2355~1.2364 g) of ammonium molybdate by adding water, and create 100 mL by preparing the ammonium molybdate test solution. Add 1 volume of 2.5 mol/L

sulfuric acid test solution and 2 volumes of acetone to one volume of ammonium molybdate test solution, shake well, and cool in ice within 30 seconds. Prepare the reaction stop coloring solution at the time of use.

Procedure:

Weigh up to three significant digits of the amount of sample required to perform the test, record the number, dissolve by adding 0.005 mol/L acetate-sodium acetate buffer adjusted to pH showing the maximum enzymatic activity of the sample so that the concentration per 1 mL becomes 0.04~0.06 phytic acid decomposition activity units. If necessary, perform filtration, use this solution as the sample solution. Weigh 0.5 mL of substrate solution by using a transfer pipette, place in a round-bottom centrifuge tube or a test tube of 10 mL, and heat at 37 ± 0.5 °C. Separately, add 0.5 mL of sample solution heated at 37 ± 0.5 °C into this substrate solution by using a transfer pipette, shake within 30 seconds, and leave for 10 minutes at 37 ± 0.5 °C. Then, add 2 mL of reaction stop coloring solution being cooled in ice by using a transfer pipette, stir well, and add 0.1 mL of 1 mol/L citric acid test solution by using the transfer pipette and stir well. For this solution, measure the absorbance OD_T at wavelength of 380 nm by water as control liquid within 5 minutes. Separately, weigh 0.5 mL of sample solution by using a transfer pipette, and add 2 mL of reaction stop coloring solution being cooled in ice by using the transfer pipette. After stirring well, add 0.5 mL of substrate solution by using the transfer pipette, and stir well, furthermore, add 0.1 mL of 1 mol/L citric acid test solution by using the transfer pipette and stir well. By operating in the same manner below, measure the absorbance OD_{TB} .

$$\text{Phytic acid decomposition power unit in 1 g} = (OD_T - OD_{TB}) \times F \times 2 \times \frac{1}{10} \times \frac{1}{W} \times Z$$

F: phosphate ion concentration corresponding to absorbance difference 1 obtained from the calibration curve ($\mu\text{mol/mL}$).

W: Sampling weight (g)

Z: Dilution

Creating a calibration curve:

Dry potassium dihydrogen phosphate for 24 hours or more in desiccator (silica gel), weigh 0.680 g (0.6795~0.6804 g), dissolve by adding water and place in a volumetric flask of 1,000 mL, and create 1,000 mL by adding more water to the marked line. Weigh 1 mL, 2 mL, 3 mL, and 4 mL of this solution by using a transfer pipette, place in a volumetric flask of 50 mL, and create 50 mL by adding water each to the marked line. Weigh 1 mL each of the solution by using the transfer pipette, add 2 mL of the reaction stop coloring solution being cooled in ice by using a transfer pipette, and stir well, furthermore, add 0.1 mL of 1 mol/L citric acid test solution by using the transfer pipette and stir well. For this solution, measure

the absorbance OD_{S1} , OD_{S2} , OD_{S3} and D_{S4} at wavelength of 380 nm by water as control liquid. Separately, weigh 1 mL of water by using a transfer pipette, add 2 mL of reaction stop coloring solution being cooled in ice by using the transfer pipette, and stir well, further, add 0.1 mL of 1 mol/L citric acid test solution by using the transfer pipette and stir well. For this solution, measure the absorbance OD_{SB} at wavelength of 380 nm by water as control liquid. Take the phosphate ion concentration to vertical axis, and take the absorbance difference ($OD_{S1} - OD_{SB}$), ($OD_{S2} - OD_{SB}$), ($OD_{S3} - OD_{SB}$), and ($OD_{S4} - OD_{SB}$) to horizontal axis, and create a calibration curve.

(b) Method 2

Preparation of substrate solution:

Weigh 0.8 g (0.75~0.84 g) of sodium phytate, dissolve by adding 0.25 mol/L acetic acid/hydrochloric acid buffer adjusted to pH 5.5, and adjust pH to 5.5 with hydrochloric acid, place in a volumetric flask of 100 mL, and create 100 mL by adding the same buffer to the marked line.

Preparation of reaction stop coloring solution:

Dissolve 100 g (99.5 g~100.4 g) of ammonium molybdate in 800 mL of water, add 10 mL of 25 % ammonia water, and create 1,000 mL by adding water, then prepare ammonium molybdate test solution. Dissolve by adding 400 mL of water warmed to 50 °C in 2.35 g (2.345 g~2.354 g) of ammonium vanadate, add 20 mL of nitric acid (1 → 3), and create 1,000 mL by adding more water, then prepare ammonium vanadate test solution. Add 1 volume of ammonium vanadate test solution and 2 volumes of nitric acid (1 → 3) into 1 volume of ammonium molybdate test solution, and mix. Prepare the reaction stop coloring solution at the time of use.

Operation:

The sample solution is prepared by the method specified in the monograph. Weigh 0.8 mL of substrate solution by using a micropipette, place in a plastic centrifuge tube of 2 mL, heat to 37 ± 0.5 °C, and leave for 5 minutes. Separately, add 0.04 mL of sample solution heated to 37 ± 0.5 °C and left for 5 minutes, and 0.36 mL of dilutions specified in the monographs by using a micropipette into this substrate solution, heat to 37 ± 0.5 °C, and leave for 30 minutes. After adding 0.8 mL of reaction stopped coloring solution by using a micropipette, stir well, and leave for 10 minutes at room temperature. Furthermore, centrifuge for 3 minutes at 14,000 revolutions per minute, measure the absorbance OD_T at wavelength of 415 nm by water as control solution for the supernatant obtained. Separately, weigh 0.4 mL of dilutions by using a micropipette or a transfer pipette, add 0.8 mL of reaction stop coloring solution and stir well, add 0.8 mL of substrate solution, and leave for 10 minutes at room temperature. Operate in the same manner below, and measure the absorbance OD_B .

$$\text{Phytic acid decomposition power unit in 1 g} = (\text{OD}_T - \text{OD}_{TB}) \times F \times 2 \times \frac{1}{30} \times \frac{1}{W} \times Z$$

F: Phosphate ion concentration corresponding to absorbance difference 1 obtained from a calibration curve ($\mu\text{mol/mL}$)

W: Sampling weight (g)

Z: Dilution ratio

Creating a calibration curve:

After drying for 2 hours at 105 °C, weigh 0.682 g (0.6815~0.6824 g) of potassium dihydrogen phosphate stored by a desiccator, dissolve by adding dilution, place in a volumetric flask of 100 mL, and create 100 mL by adding more dilution to the marked line. Weigh 3 mL, 6 mL, 12 mL, and 25 mL of this solution by using a transfer pipette, place each in volumetric flasks of 50 mL, and create 50 mL by adding the dilution each to the marked lines. Follow the same procedure as the sample solution, and measure OD_{S1} , OD_{S2} , OD_{S3} and OD_{S4} . Take phosphate ion concentration to vertical axis, and take the absorbance difference ($\text{OD}_{S1} - \text{OD}_B$), ($\text{OD}_{S2} - \text{OD}_B$), ($\text{OD}_{S3} - \text{OD}_B$), and ($\text{OD}_{S4} - \text{OD}_B$) to horizontal axis, and create a calibration curve.

(C) Method 3

In preparation

(D) Method 4

In preparation

I. Pectin liquefying power test method

Pectin liquefaction power test method is a method by measuring the amount of pectin in feed additive by the viscosity of the pectin decreases with overall low molecular weight of pectin when pectinase acts on pectin, and the unit is indicated as pectin liquefying power unit. When pectinase acts on 1 % of pectin solution for 10 minutes at 37 °C, 1 pectin liquefying power unit corresponds to the amount of enzyme that reduces its viscosity to half.

Device:

Use a viscometer shown in the figure as a measurement device.

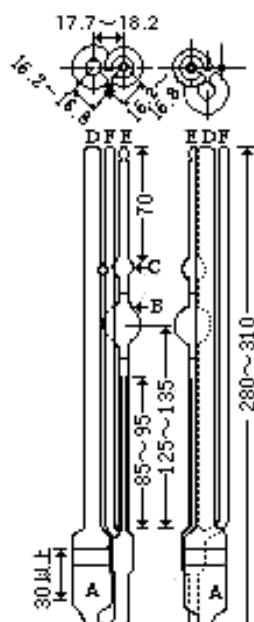

Number unit: mm

Preparation of substrate solution:

Weigh up to digit 0.01 g of about 1 g of pectin in advance, record the number, dry for 2 hours at 105 °C, and measure the weight loss. Weigh up to digit 0.01 g of pectin corresponding to 2.0 g of the dried product, add 50 mL of water, dissolve by heating, place in a volumetric flask of 100 mL, and create 100 mL by adding water to the marked line after cooling.

Procedure:

Weigh up to three significant digits of the amount of sample required to perform the test, record the number, dissolve by adding 0.2 mol/L acetate-sodium acetate buffer adjusted to pH showing the maximum enzymatic activity of the sample so that the concentration per 1 mL each becomes about 0.5 pectin liquefying power units, about 1.0 pectin liquefying power units, and about 2.0 pectin liquefying power units, and indicate these as the sample solution A, B, and C. Place 5 mL of substrate solution and 4 mL of 0.2 mol/L acetate-sodium acetate buffer adjusted to pH showing the maximum enzymatic activity of the sample in a ball A through a pipe D of viscometer, leave for 10 minutes in a water bath at 37 ± 0.5 °C, add 1 mL of sample solution A, shake well within 30 seconds, and leave for 10 minutes in a water bath at 37 ± 0.5 °C. After raising the liquid surface to the center of a ball C by gently sucking from a tube E of viscometer, stop the suction, pass down by gravity within 30 seconds, and measure the time t_{a1} to require for the liquid surface to flow down from a marked line to a lower marked line on a ball B. Separately, place 5 mL of water and 4 mL of 0.2 mol/L acetate-sodium acetate buffer adjusted to pH showing the maximum enzymatic activity of the sample in the ball A through the pipe D of viscometer, leave for 10 minutes in a water bath at 37 ± 0.5 °C, add 1 mL of the sample solution A, shake well within 30

seconds, and leave for exactly 10 minutes in a water bath at 37 ± 0.5 °C. Operate the viscometer in the same manner below, measure the flow time t_{a2} , to obtain T_A ($t_{a1} - t_{a2}$). Next, separately, for the sample solution B and C, operate in the same manner as the sample solution A, and obtain T_B ($t_{b1} - t_{b2}$) and T_C ($t_{c1} - t_{c2}$). Furthermore, separately, place 5 mL of substrate solution and 5 mL of 0.2 mol/L acetate-sodium acetate buffer adjusted to pH showing the maximum enzymatic activity of the sample in the ball A through the pipe D of viscometer, shake well within 30 seconds, and leave for 10 minutes in a water bath at 37 ± 0.5 °C. Operate the viscometer in the same manner below, and measure the flow time t_{01} . Separately, place 5 mL of water and 5 mL of 0.2 mol/L acetate-sodium acetate buffer adjusted to pH showing the maximum enzymatic activity of the sample in the ball A through the pipe D of viscometer, shake well within 30 seconds, and leave for 10 minutes at 37 ± 0.5 °C. Operate the viscometer in the same manner below, and measure the flow time t_{02} to obtain T_0 ($t_{01} - t_{02}$). Take T_A , T_B and T_C to vertical axis of semi-log graph, and take weighed amount (g) of the sample contained in 1 mL each of the sample solution of A, B and C to horizontal axis (logarithmic scale), and obtain the amount W (g) of the sample corresponding to $T_0/2$.

$$\text{Pectin liquefying power unit in 1 g} = \frac{1}{W}$$

J. Pectin saccharification power test method

Pectin saccharification power test method is a method by measuring the amount of pectin in feed additive by reducing power to increase with the hydrolysis when pectinase acts on pectin. The unit is indicated as pectin saccharification power unit. When pectinase acts on pectin at 40 °C, 1 pectin saccharification power unit corresponds to the amount of enzyme leading to an increase in the reducing power corresponding to the reducing power of 1 μ mol of galacturonic acid in 1 hour of the initial stage of the reaction.

Preparation of substrate solution

Weigh 0.65 g (0.645 g~0.654 g) of pectin, dissolve by shaking vigorously while adding the pectin slowly to citrate buffer adjusted to pH showing the maximum enzymatic activity of the sample, place in a volumetric flask of 100 mL, and create 100 mL by adding more buffer to the marked line.

Procedure:

Weigh up to three significant digits of the amount of sample required to perform the test, record the number, dissolve by adding citrate buffer adjusted to pH showing the maximum enzymatic activity of the sample so that the concentration per 1 mL becomes 25~35 pectin saccharification power units. Then use this solution as the sample solution. When this is not completely melted, leave for 1 hour by stirring occasionally, centrifuge, and use the supernatant as sample solution. Weigh 10 mL of substrate solution by using a transfer pipette, place in iodine flask of 100 mL,

leave for 5 minutes in a water bath at 40 ± 0.2 °C, add 1 mL of sample solution by using a transfer pipette, and shake well within 30 seconds, then leave for exactly 1 hour in a water bath at 40 ± 0.2 °C. Next, add 2.5 mL of sodium carbonate test solution, and shake well, further, add 5 mL of 0.1 mol/L iodine solution by using a transfer pipette and shake well, leave in the dark for 40 minutes, add 5 mL of sulfuric acid (12 → 100), shake well, and titrate with 0.01 mol/L sodium thiosulfate solution within 30 seconds (indicator, 1 mL of starch test solution). In this case, the end point of the titration is the time when the blue color of the solution disappears, and the titer is A mL. Separately, weigh 10 mL of substrate solution by using a transfer pipette, place in iodine flask of 100 mL, add 2.5 mL of sodium carbonate test solution, and after shaking well, add 1 mL of sample solution by using a transfer pipette, shake well, further, add 5 mL of 0.1 mol/L iodine solution by using a transfer pipette, and shake well. Operate in the same manner below, and the titer is B mL.

$$\text{Pectin Saccharification power unit in 1 g} = ((B - A) \times 2 - 3) \times 0.01 \times 513 \times \frac{1}{W}$$

W: The amount of sample in 1 mL of the sample solution (g)

K. Peptidoglycan Degradation Test

The peptidoglycan degradation test is a method to measure the amount of muramidase in a feed additive by the fluorescence intensity that increases with hydrolysis when the muramidase acts on fluorescently labeled peptidoglycan, and the unit is expressed as the peptidoglycan unit.

One peptidoglycan unit corresponds to the amount of enzyme that increases the fluorescence intensity equivalent to 0.06 nmol of fluorescein isothiocyanate (isomer I) per minute when muramidase acts on fluorescein-labeled peptidoglycan at pH 6.0 and 30°C.

Diluent:

Weigh 22.5 g (22.45 to 22.54 g) of sodium monohydrogen phosphate dihydrate and 7.74 g (7.735 to 7.744 g) of citric acid, transfer them into a 1000-mL volumetric flask, add 800 mL of water, stir until dissolved, add 1 mL of octylphenol ethoxylate TS, and adjust the pH to 5.9 to 6.1 with 0.05 mol/L sodium hydroxide TS or 0.1 mol/L hydrochloric acid TS. Add water to the marked line.

Preparation of substrate solution:

Mix 100 µL of 0.5 mg/mL fluorescein-labeled peptidoglycan TS with 1900 µL of diluent. Prepare this solution before use.

Procedure:

Measure up to three significant digits of the sample required for the test, record the value, add the diluent so that the concentration per mL is between 0.01 and 0.03 peptidoglycan units, and use the

solution obtained by stirring for 45 to 90 minutes as the sample solution.

Dispense 50 μL of each of the standard solutions A to G and the sample solution into the microplate (black), and 100 μL of the diluent into the adjacent wells that are not used. Quickly dispense 50 μL of the substrate solution into the wells containing the standard solutions A to G and the sample solution, and immediately measure the fluorescence intensity for 30 minutes with a fluorescence microplate reader set to an excitation wavelength of 485 nm, a fluorescence wavelength of 528 nm, and a temperature of 30°C at a measurement interval of one minute.

img1:

F: Peptidoglycan unit determined from calibration curve

V: Amount of sample solution prepared

Z: Dilution factor of the sample solution

W: Sampling amount (g)

Creating calibration curve:

Take muramidase equivalent to 70,000 peptidoglycan units, add a suitable amount of diluent, dissolve by stirring well for 45 to 90 minutes, transfer it into a 100-mL volumetric flask, and add diluent to the marked line to make 100 mL. Transfer 50 μL of this solution into a 100-mL volumetric flask, add diluent to the marked line to make 100 mL, and use this solution as the standard stock solution. Dilute this solution with diluent according to the following table, and use these solutions as standard solutions A to G.

Standard solution	Dilution factor	Amount of standard stock solution (μL)	Diluent volume (μL)	Peptidoglycan unit/mL
A	40	30	1,170	0.0088
B	30	40	1,160	0.012
C	24	50	1,150	0.015
D	20	60	1,140	0.018
E	15	80	1,120	0.023
F	12	100	1,100	0.029

G	10	120	1,080	0.035
---	----	-----	-------	-------

Calculate the increase in fluorescence intensity per minute (slope) from each of the measured values of standard solutions A to G from 0 to 30 minutes. Prepare a calibration curve with the calculated slope on the vertical axis and the peptidoglycan unit per mL of each standard solution on the horizontal axis.

L. Lactase test method

Lactase test method is a method by measuring the amount of lactase in feed additive by the amount of *o*-nitrophenol produced by hydrolysis when lactase acts on *o*-nitrophenyl- β -D-galactopyranoside, and the unit is indicated as lactase unit. When lactase acts on *o*-nitrophenyl- β -D-galactopyranoside at 30 °C, 1 lactase unit corresponds to the amount of enzyme that 1 μ mol of *o*-nitrophenyl- β -D-galactopyranoside hydrolyze in one minute of the initial stage of the reaction.

Preparation of substrate solution:

Weigh 0.172 g (0.1715~0.1724 g) of *o*-nitrophenyl- β -D-galactopyranoside, dissolve in Makkirubein buffer adjusted to pH showing the maximum enzymatic activity of sample, place in a volumetric flask of 100 mL, and create 100 mL by adding the same buffer to the marked line.

Procedure:

Weigh up to three significant digits of the amount of sample required to perform the test, record the number, dissolve by adding water so that the concentration per 1 mL becomes 0.05~0.08 lactase units, and use this solution as the sample solution. If this is not completely melted, leave for 1 hour by stirring occasionally, centrifuge, and use the supernatant as sample solution. Weigh 3.5 mL of substrate solution by using a transfer pipette, warm to 30 °C, and add 0.5 mL of sample solution by using a micropipette or a transfer pipette. After leaving for 10 minute at exactly 30 °C, add 1 mL of sodium carbonate test solution by using a transfer pipette and shake, and for this solution, measure the absorbance A_T at wavelength of 420 nm. Separately, weigh 3.5 mL of substrate solution by using a transfer pipette, warm to 30 °C, and add 1 mL of sodium carbonate test solution by using a transfer pipette. After shaking well, further, add 0.5 mL of sample solution by using a micropipette or a transfer pipette, leave for 10 minutes at exactly 30 °C, and for this solution, measure the absorbance A_T' as well.

$$\text{Lactase unit in 1 g} = \frac{A_T - A_T'}{0.90} \times \frac{1}{10} \times \frac{2}{W}$$

W: The amount of sample in 1 mL of the sample solution (g)

(15) 1, 4-Dioxane Limit Test

1,4-Dioxane Limit Test is a limit test of the quantity of 1,4-dioxane contained as impurities in the emulsifying agents.

Apparatus:

Use the apparatus illustrated in figure.

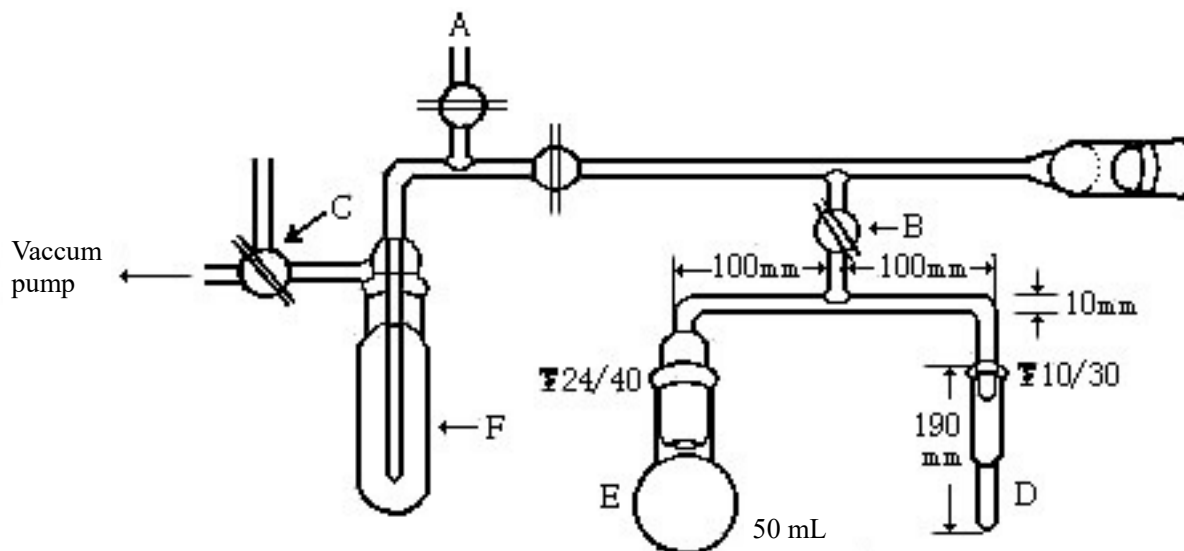

A: Manometer

B: Two-way stopcock

C: Three-way stopcock

D: Concentrator (quartz, measure exactly 0.9 mL or more of distillate, and put a mark in order to dilute to exactly 2.0 mL.)

E: Round-bottomed flask

F: Vacuum trap

Procedure:

Weigh 20 g of the sample to two decimal places, record the value, and place in a round-bottomed flask E. In the case where the sample is in semisolid or waxy, heat on a water bath to effect a liquid, place in the round-bottomed flask E. In the case where the sample is in crystalline, add 1.5 mL of water, in the case where the sample is in semisolid or waxy, add 1.0 mL of water. If the water content of the sample is large, adjust the absolute quantity of water to 1.0 to 1.5 mL. Mix well the sample and water with a magnetic stirrer, immerse the flask E in an ice bath, and cool for about 1 minute. Then, wind ribbon heater in round a connecting tube between the flask E and the concentrator D, and carry out electrophoresis at about 10 to 15 V. Attach the flask E and the concentrator D to the distillation apparatus, and apply silicone grease for high vacuum to each joint. Immerse the vacuum trap F in the dewar flask filled with liquid nitrogen, close the cock B, then open the cock C and start operating the vacuum pump. Immerse the flask E in a dry ice-

methanol bath for about 10 minutes, when the degree of vacuum becomes not exceeding 0.007 kPa, open the cock B for 20 seconds, then close again. Remove a dry ice-methanol bath, allow to stand for 1 minute under room temperature, and immerse for about 5 minutes in a water bath at 20 ~ 25 °C. Increase the temperature up to 35 ~ 40 °C (most of the sample dissolves.), dissolve the sample completely with a magnetic stirrer, cool in an ice water for 2 minutes. Then, replace a water with a dry ice-methanol bath, immerse for about 10 minutes, freeze the contents, open the cock B for 20 seconds, and close again. Remove a dry ice-methanol bath, immerse in a water bath, increase the temperature up to 45 to 50 °C, and stir until the sample completely dissolves. If the concentrates are recognized in the connecting tube between the flask E and the concentrator D, heat until the concentrates disappears by slowly raising the voltage of the ribbon heater. Immerse the concentrator D in the dewar flask filled with liquid nitrogen slowly and carefully not to damage while stirring the sample. After the beginning of distillation and generation of ice in the concentrator D, raise gradually the dewar flask to maintain the surface of liquid nitrogen slightly below the surface of the ice. When the water freezes up to the neck of the concentrator D, or when raising the surface of liquid nitrogen to the mark of 2.0 mL of the concentrator D, remove the dewar flask and melt ice under room temperature. After melting the ice, repeat warming and cooling continuously until the amount of distilled water becomes not less than 0.9 mL. Cool the concentrator D for 2 minutes again to freeze the contents, release by opening the cock C, stop operating the vacuum pump, and open the cock B. Remove the concentrator D, stopper, and melt the ice under room temperature. To the concentrator D add water to make exactly 2.0 mL, stir uniformly, and use this solution as the sample solution. Perform the test with the sample solution and standard solution for 1,4-dioxane limit test as directed under Gas Chromatography method according to the following conditions, and calculate the height of each peak.

Operating Conditions:

Detector: A hydrogen flame-ionization detector.

Column: with a glass or a stainless steel column about 3 mm in inside diameter and about 2.0 m in length, packed with 149 ~ 177 µm porous acrylonitrile-divinylbenzene copolymer for gas chromatography, or equivalent.

Column temperature: 140 ~ 150 °C in constant.

Carrier gas and flow rate: Adjust the flow rate of nitrogen so that the retention time of dioxane is about 40 minutes.

Preparation of standard solution for 1,4-dioxane limit test:

Weigh 1.000 g (0.9995~1.0004 g) of dioxane, dissolve in water, place in a 100 mL volumetric flask, and add water to make exactly 100 mL. Measure 1 mL of this solution with a transfer pipet, place in a 100 mL volumetric flask, and add water to make exactly 100 mL. Preserve in a cool place, and use within a week.

(16) Heavy Metals Limit Test

Heavy Metals Limit Test is a limit test of the quantity of heavy metals contained as impurities in samples. The heavy metals are the metallic inclusions that are darkened with sodium sulfide test solution in acidic solution, as their quantity is expressed in terms of the quantity of lead (Pb).

In each monograph, the permissible limit for heavy metals (as Pb) is described in terms of mg/kg in parentheses.

Procedure:

Unless otherwise specified, sample solutions and control solutions are prepared as directed in the following.

A. Method 1

Place an amount of the sample, directed in the monograph, in a Nessler tube. Dissolve in water to make 40 mL. Add 2 mL of dilute acetic acid and water to make 50 mL, and designate it as the sample solution.

The control solution is prepared by placing the volume of standard lead solution directed in the monograph, in a Nessler tube, and adding 2 mL of dilute acetic acid and water to make 50 mL.

B. Method 2

Place an amount of the sample, directed in the monograph, in a quartz or porcelain crucible, cover loosely with a lid, and carbonize by gentle ignition. After cooling, add 2 mL of nitric acid and 5 drops of sulfuric acid, heat cautiously until white fumes are no longer evolved, and incinerate by ignition between 500 °C and 600 °C. Cool, add 2 mL of hydrochloric acid, evaporate to dryness on a water bath, moisten the residue with 3 drops of hydrochloric acid, add 10 mL of hot water, and warm for 2 minutes. Then add 1 drop of phenolphthalein test solution, add ammonia test solution dropwise until the solution develops a pale red color, add 2 mL of dilute acetic acid, filter if necessary, and wash with 10 mL of water. Transfer the filtrate and washings to a Nessler tube, and add water to make 50 mL. Designate it as the sample solution.

The control solution is prepared as follows: Evaporate a mixture of 2 mL of nitric acid, 5 drops of sulfuric acid and 2 mL of hydrochloric acid on a water bath, further evaporate to dryness on a sand bath, and moisten the residue with 3 drops of hydrochloric acid.

Hereinafter, proceed as directed in the sample solution, then add the volume of standard lead solution directed in the monograph and water to make 50 mL.

C. Method 3

Place an amount of the sample, directed in the monograph, in a quartz or porcelain crucible, heat cautiously, gently at first, and then incinerate by ignition. After cooling, add 1 mL of aqua regia, evaporate to dryness on a water bath, moisten the residue with 3 drops of

hydrochloric acid, add 10 mL of hot water, and warm for 2 minutes. Add 1 drop of phenolphthalein test solution, add ammonia test solution dropwise until the solution develops a pale red color, add 2 mL of dilute acetic acid, filter if necessary, wash with 10 mL of water, transfer the filtrate and washings to a Nessler tube, and add water to make 50 mL. Designate it as the sample solution.

The control solution is prepared as follows: Evaporate 1 mL of aqua regia to dryness on a water bath. Hereinafter, proceed as directed for the test solution, and add the volume of standard lead solution directed in the monograph and water to make 50 mL.

Add 1 drop of sodium sulfide test solution to each of the sample solution and the control solution, mix thoroughly, and allow to stand for 5 minutes. Then compare the colors of both solutions by viewing the tubes downward or transversely against a white background.

The sample solution has no more color than the control solution.

(17) Water Determination (Karl Fischer Method)

Water Determination is a method to determine water content in sample materials, utilizing the fact that water reacts with iodine and sulfur dioxide quantitatively in the presence of methanol and pyridine. The reaction proceeds in the manner shown in the following equation:

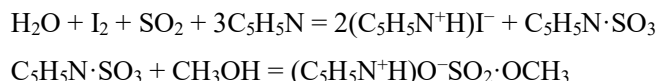

Apparatus:

Generally, the apparatus consists of two of automatic burette, a titration flask (250 mL), a stirrer, and equipment for amperometric titration at constant voltage or potentiometric titration at constant current.

The Karl Fischer test solution for water determination is extremely hygroscopic, so the apparatus should be designed to be protected from atmospheric moisture. Desiccants such as silica gel or calcium chloride (for water determination) are used for moisture protection.

Reagents and test solutions:

Methanol for Karl Fischer: Add 5 g (4.5~5.4 g) of magnesium powder to 1,000 mL of methanol, attach a reflux condenser connected a water absorbing tube (calcium chloride for water determination), and heat, add 0.1 g (0.05~0.14 g) of mercury (II) chloride to enhance the reaction if necessary. After the evolution of gas is stopped, distill the methanol protecting it from moisture, and preserve protecting from moisture. The water content of methanol for Karl Fischer should be not more than 0.5 mg per 1 mL.

Pyridine for Karl Fischer: Add potassium hydroxide or barium oxide to pyridine, stopper tightly, and allow to stand for several days. Distill and preserve the purified and dried pyridine,

protecting it from moisture. The water content of this pyridine should not be more than 1 mg per mL.

Karl Fischer test solution:

Preparation: Dissolve 63 g (62.5~63.4 g) of iodine in 100 mL of pyridine for Karl Fisher, cool the solution in ice bath, and pass dried sulfur dioxide gas through this solution until the mass increase of the solution reaches 32.3 g. Then make up to 500 mL by adding methanol for Karl Fisher, and allow to stand for more than 24 hours before use. Standardize before use since this solution changes over time, preserve in a cold place, protecting it from light and moisture.

Standardization: According to the procedure described below, take 25 mL of methanol for Karl Fischer in a dried titration flask, and titrate the solvent with a Karl Fischer test solution to make the inside of the flask anhydrous. Then, weigh about 50 mg of water to one decimal place, put in the titration flask within 30 seconds, and titrate the water dissolved in the solvent with a Karl Fischer test solution to the end point, under vigorous stirring. Calculate the water equivalence factor, f (mg/mL), corresponding to the amount of water (H_2O) in mg per mL of the Karl Fischer test solution by using the following equation:

$$f = \frac{\text{Amount of water taken } (H_2O) \text{ (mg)}}{\text{Volume of Karl Fisher test solution consumed for titration of water } (H_2O) \text{ (mL)}}$$

Standard water-methanol solution:

Preparation: Take 500 mL of methanol for Karl Fischer in a dried 1,000 mL volumetric flask, add 2.0 mL of water, and adjust with the methanol for Karl Fisher to make 1,000 mL.

Standardization of standard water-methanol solution is proceeded by following standardization of Karl Fischer test solution. Preserve in a cold place, protecting it from light and moisture.

Standardization: According to the procedure described below, take 25 mL of methanol for Karl Fischer in a dried titration flask, and titrate the water contaminated with Karl Fischer test solution to make the content of the flask anhydrous. Then, add 10 mL of Karl Fischer test solution with a transfer pipet to this solution in the flask, and titrate it with the prepared standard water-methanol solution to the end point. Calculate the water concentration in the standard water-methanol solution, f' (mg/mL), by using the following equation:

$$f' = \frac{f \times 10}{\text{Volume of the standard water-methanol solution consumed for the titration (mL)}}$$

Procedure:

As a rule, the titration of water with Karl Fischer test solution should be performed at the same temperature as that which the standardization was done, with protection from moisture. The apparatus is equipped with a variable resistor in the circuit, and this resistor is manipulated so as

to maintain a constant current (5~10 μA) between two platinum electrodes immersed in the solution to be titrated. During titration with Karl Fischer test solution, the needle of the microammeter in the circuit varies noticeably, but returns to the original value within several seconds. At the end of a titration, the changing of the needle of the microammeter (50~150 μA) and persists for longer than 30 seconds. When this electric state has been attained, it is designated as the end point of titration. In the case of back titration, the needle of the microammeter is out of scale during excessive presence of Karl Fischer test solution, and it returns rapidly to the original position when the titration system has reached the end point. Potentiometer with magic eye tube are available instead of microammeters.

Unless otherwise specified, the titration of water with Karl Fischer test solution is performed by either one of the following methods. Usually, the end point of the titration can be observed more clearly in the back titration method, compared with the direct titration method.

A. Direct titration

Unless otherwise specified, proceed by the following method.

Take 25 mL of methanol for Karl Fischer in a dried titration flask, and titrate the water contaminated with Karl Fischer test solution to make the content of the flask anhydrous. Weigh a quantity of sample specimen containing 10 to 50 mg of water to three significant digits, record the value, transfer it into the titration flask within 30 seconds, dissolve by stirring, and titrate the solution to be examined with Karl Fischer test solution to the end point while stirring vigorously. In the case of an insoluble sample specimen, powder the sample quickly, weigh, and transfer it into the titration vessel within 30 seconds. After stirring for 5 to 30 minutes, with protection from moisture, perform the titration under vigorous stirring.

$$\text{Water (H}_2\text{O) \%} = \frac{\text{Volume of Karl Fischer test solution consumed for titration (mL)} \times f}{\text{Amount of sample (mg)}} \times 100$$

B. Reverse Titration

Unless otherwise specified, proceed by the following method.

Take 25 mL of methanol for Karl Fischer in a dried titration flask, and titrate the water contaminated with Karl Fischer test solution to make the content of the flask anhydrous. Weigh a quantity of sample specimen containing 10~50 mg of water to three significant digits, record the value, transfer it into the titration flask within 30 seconds, add an excessive and definite volume of Karl Fisher test solution, dissolve by stirring, and titrate the solution to be examined with standard water-methanol solution to the end point while stirring vigorously. In the case of an insoluble sample specimen, powder the sample quickly, weigh, and transfer it into the titration vessel within 30 seconds. After stirring for 5~30 minutes, with protection from moisture, perform the titration under vigorous stirring.

$$\text{Water (H}_2\text{O) \%} = \frac{\left\{ \frac{[\text{Volume of Karl Fisher test solution added (mL)}] \times f}{[\text{Volume of the standard water-methanol solution consumed for titration (mL)}] \times f} \right\}}{\text{Amount of sample (mg)}} \times 100$$

(18) Viable Bacteria Agent Test Method

Viable Bacteria agent test method is a test method by conducting the identification of viable bacteria in sample by chemical or microbiological methods. Water, reagent, test solutions, meter, and instrument used for this test must be germfree as needed.

Types, composition and pH of medium

Except otherwise specified, use those having the composition and pH listed in the following table. However, when specifying simply "peptone" as a component of medium, casein peptone can safely be used. For the preparation of pH of the medium, use 1 mol/L hydrochloric acid reagent or 1 mol/L sodium hydroxide test solution, and determine pH after sterilization as being specified.

Composition of medium and pH											
Medium number		1	2	3	4	5	6	7	8	9	10
Composition of medium in 1,000m	Pepton made of casein (g)	5	20	20	10	5	17		10	15	
	Protease pepton (g)	10							10		
	Soy pepton (g)	3					3		3	5	
	Pepton (g)							10			
	Essence of meat (g)	2.4	10	10	5			5	2.2		
	Sodium chloride (g)	0.01	1.5	1.5	5	0.01	5		3	5	5
	Yeast extract (g)	5	2.2	2.2		5			5		
	Liver essence (g)	3.2							1.2		
	Glucose (g)	10				2	2.5	10			
	Lactose (g)		20	20							
	Polysorbate 80 (mL)	1	1							1	
	soluble starch (g)	0.5									
	Potassium dihydrogenphosphate (g)	1				0.5			2.5		
	Dibasic potassium phosphate (g)	1				0.5	2.5				
	Magnesium sulphate (g)	0.2				0.3					
	Ferrous sulphates (g)	0.01				0.01					
	Maganese sulphate (g)	0.007				0.01					
	Zinc sulfata (g)					0.001					
	Cobalt sulphates (g)					0.001					
	Copper sulfate (g)					0.001					
	L-cystein hydrochloride mono-hydrate (g)	0.5							0.3		
	Silicone (g)	0.2									
	Dijestion serum (g)								13.5		
	Sodium thyoglycollate (g)								0.3		
	Extraction liquid of bovine hear (g)										500
	Tryptose (g)										10
	Bromcresol purple test solution (mL)										1
Agar (g)	15		15	15	15	15	20			15	
Water (g)		Proper quantity	Proper quantity	Proper quantity	Proper quantity	Proper quantity	Proper quantity	Proper quantity	Proper quantity	Proper quantity	Proper quantity
pH after sterilization		7.1~7.3	6.9~7.1	6.9~7.1	6.9~7.1	5.9~6.1	7.2~7.4	6.4~7.0	7.2~7.4	7.2~7.4	7.3~7.5

Note 1) No. 1 medium and No. 9 medium, shall be used after sterilization by being added horse 5mL of defiberination to 100mL of the solution.

2) Adjustment of pH for No.5 medium shall be conducted by using 1 mol/L sodium hydroxide test solution or dilute sulphic acid.

A. Stain Method

Stain method is a test method by determining presence of physical and chemical nature, shapes, and spores of viable bacteria by staining viable bacteria with appropriate stain.

(a) Gram Staining Method: Use one suitable method of two below.

i. Variant of Hucker

Add 2 drops of Hucker stain to fixed sample by smearing on a slide glass, and after staining by leaving for 30 to 60 seconds, drain off the liquid by shaking the slide glass gently. Next, add enough Lugol's solution, leave for 60 seconds, wash with water, and absorb water by filter paper. Bleach until the washing solution becomes almost colorless by using absolute ethanol or ethanol- acetone mixture (7:3) as bleaching solution while moving the slide glass gently. Thereafter, wash with water, absorb water by filter paper, add 2 drops of safranin solution (1 → 200), and leave 60 seconds. After performing post-staining (counterstained), wash with water, and dry.

ii. Variant of Lillie

Add 2 drops of Lillie stain to fixed sample by smearing on a slide glass, and after staining by leaving for 30 seconds, drain off the liquid by shaking the slide glass gently. Next, after washing with iodine-Lugol reagent several times, add 3 drops of iodine-Lugol reagent, and leave for 30 seconds. After rinsing thoroughly with iodine-acetone reagent sufficiently, add 3 drops of iodine-acetone reagent, and leave for 30 seconds. Then, wash with water, and absorb water by filter paper. Add 2 drops of weak carbol-fuchsin solution, leave for 30 seconds, and after performing post-staining (counterstained), wash with water, and dry.

(b) Spore Staining Method: Wirtz Method (Variant of Schaeffer-Fulton)

Smear on a slide glass, and after staining fixed sample by warming or heating for 1~3 minutes by using malachite green solution (1 → 20), wash with water for about 30 seconds, and dry. Add 1~3 drops of safranin solution (1 → 200) to the dried smear surface, and after staining for 15 to 30 seconds, wash with water, and dry.

B. Glycolytic Capacity Test Method

Glycolytic capacity test method is a test method to determine presence of glycolytic capacity of viable bacteria by measuring pH of culture solution by culturing viable bacteria. Use one suitable method of two below.

(a) Method 1

Pick the colony formed on the medium specified in each monograph with a platinum loop, and after filtering and sterilizing 10 mL of the medium No. 8 and aqueous solution of saccharide (3 → 10) directed in the monographs, inoculate to 10 mL each of the medium No. 8 adding 0.3 mL of the filtrate, culture anaerobically for 7 days at 36~38 °C, and use this solution as sample solution and standard solution. Measure pH of the standard solution and the sample solution by pH measurement method, and determine the value of less than 1 after subtracting the pH of the sample solution from the pH of the standard solution as negative, and more than 1 as positive.

(b) Method 2

Pick the colony formed on the medium specified in each monograph with a platinum loop, and after filtering and sterilizing aqueous solution of saccharide (3 → 10) directed in the monographs, inoculate to 3 mL each of the medium No. 10 adding 0.1 mL of the filtrate, culture anaerobically for 7 days at 36~38 °C, and use this solution as sample solution and standard solution. Separately, after filtering and sterilizing 3 mL of the medium No. 10 as negative control and glucose solution (3 → 10) as positive control, inoculate each bacteria to 3 mL of the medium No. 10 adding 0.1 mL of the filtrate, and operate the same procedure. Determine the sample solution being bluish purple as negative, and being yellow as positive. At the same time, confirm that the negative control is blue-violet, and the positive control is yellow color.

C. Lactic Acid Production Capacity Test Method

Lactic acid producing ability test method is a test method to determine presence of lactic Acid Production Capacity in viable bacteria by measuring the lactic acid in culture solution by culturing viable bacteria.

Preparation of standard solution and sample solution

Unless otherwise specified, perform by the following method.

Pick the colony formed on the sample stock solution or the medium specified in each monograph with a platinum loop, inoculate to 10 mL of the medium No. 2, culture for 7 days at 36~38 °C, and use this solution as sample solution. Place 1.0 mL of the sample stock solution in a test tube of 10 mL with stopper, add 0.25 mL of sulfuric acid (1 → 2) and 2 mL of ether, and after inverting 20 times gently, leave still and take the upper layer, place in a separate test tube of 10 mL with stopper, add same amount of water, operate by the same procedure, take the lower layer, filter this with a membrane filter (pore size of 0.45 µm or less), and create sample solution. Create 100 mL by adding water to 1.0 mL of lactic acid, and define this as standard stock solution. Create 100 mL by adding water to 1.0 mL of the standard stock solution, and define this as standard solution by filtering with a membrane filter (pore size of 0.45 µm or less). Water for the use needs to be purified for liquid chromatography.

However, culture *Enterococcus Faecalis*, *Enterococcus Faecium*, and *Bacillus Core Glance* aerobically, and *Lactobacillus Acidophilus* and *Lactobacillus Salivarius* anaerobically.

Procedure

When performing the test by liquid chromatography method under the following conditions for 20 µL each of sample solution and standard solution, the retention time of the peaks obtained from the sample solution matches the retention time of the peaks obtained from the standard solutions.

Operating Conditions

Detector: Ultraviolet absorption photometer (measurement wavelength: 210nm)

Column: with a stainless steel column about 4.6 mm in inside diameter and about 150 mm in length, packed with octadecylsilyl silica gel of particle size 5 µm for liquid chromatograph.

Column temperature: 40 °C

Mobile phase: Phosphate (1 → 1,000)

Flow rate: About 1.0 mL per minute

D. Butyric Acid Generation Capacity Test Method

Butyric acid generating capacity test method is a test method to determine presence of butyric acid generating capacity of viable bacteria by measuring the acid in culture medium by culturing viable bacteria.

Preparation of sample solution and standard solution

Pick the colony formed on the sample stock solution or the medium specified in each monograph with a platinum loop, inoculate to 10 mL of the medium No. 7, culture for 7 days at 36~38 °C anaerobically, and use this solution as sample stock solution. Place 1.0 mL of the sample stock solution in a test tube with stopper, add 0.25 mL of sulfuric acid (1 → 2) and 2 mL of ether, and after inverting 20 times gently, leave still and take the upper layer, place in a test tube of 10 mL with stopper, add the same amount of water, operate by the same procedure, take the lower layer, and define this as sample solution by filtering with a membrane filter (pore size 0.45 µm or less). Create 100 mL by adding water to 1.0 mL of butyric acid, and define this as standard stock solution. Create 100 mL by adding water to 1.0 mL of the standard stock solution, and define this as standard solution by filtering with a membrane filter (pore size 0.45 µm or less). Water for the use needs to be purified for liquid chromatography.

Procedure

When performing the test by liquid chromatography method under the following conditions for 20 µL each of sample solution and standard solution, the retention time of the peaks obtained from the sample solution matches the retention time of the peaks obtained from the standard solutions.

Operating Conditions

Detector: Ultraviolet absorption photometer (measurement wavelength: 210 nm)

Column: with a stainless steel column about 4.6 mm in inside diameter and about 150 mm in length, packed with octadecylsilyl silica gel of particle size 5 µm for liquid chromatograph.

Column temperature: 40 °C

Mobile phase: Phosphate (1 → 1,000)

Flow rate: About 1.0 mL per minute

(19) Viable Bacteria Agent Quantitation Method

Viable bacteria agent quantitative method is a test method by measuring the number of bacteria of viable bacteria in sample by microbiological method. Use water, reagent, test solutions, meter, and instrument being used for this test must be germfree as needed.

Dilution

Use dilution by sterilizing those having composition and pH listed below.

Dilution No. 1 (pH 7.0): Dissolve by adding 750 mL of water to 1 g (0.5~1.4 g) of casein peptone and 5 g (4.5~5.4 g) of sodium chloride, and after adjusting pH to 6.9~7.1, create 1,000 mL by adding more water.

Dilution No.2 (pH 7.0): Dissolve by adding 750 mL of water to 4.5 g (4.45~4.54 g) of potassium dihydrogen phosphate, 6 g (5.5~6.4 g) of dodecahydrate sodium hydrogen phosphate, 0.5 g (0.45~0.54 g) of polysorbate 80, 0.5 g (0.45~0.54 g) of L-cysteine hydrochloride monohydrate, and 0.5 g (0.45~0.54 g) of agar, and after adjusting pH to 6.9~7.1, create 1,000 mL by adding more water.

Types, the composition and pH of medium

Apply the section of Viable Bacteria Agent Test Method (18).

Preparation of sample solution

Unless otherwise specified, perform by the following method.

Weigh up to digit 0.001 g of 1 g of this product, record the number, add 50 mL of dilution by using whole pipette and shake well, and define as sample stock solution. Weigh 1 mL of this stock solution by using whole pipette, and separately, add 9 mL of dilution weighed by using whole pipette, and dilute this to 10 times. Perform this procedure repeatedly, prepare concentration containing from 30~300 or containing from 300~3,000 viable bacteria in 1 mL, and use this solution as sample solution. Use surfactant during dilution as needed.

Procedure

Use method 1 in the case of concentration containing from 30~300 viable bacteria in 1 mL of the sample solution, and method 2 in the case of concentration containing from 300~3,000 viable bacteria in 1 mL of the sample solution

A. Method 1

Place 1 mL each of sample solution in five petri dishes, add 20 mL each of agar medium for the test kept at 50 °C thereto, and mix and solidify within 30 seconds. If necessary, make a base layer by the agar medium on the bottom of the petri dish for the test, and after performing the procedure above, make multi layers by adding more test agar medium. Count the colonies that appeared in the culture period specified in the monographs at 36~38 °C, and determine the average number of the colonies.

Number of viable bacteria in 1 g of sample

$$= \frac{\text{Average number of colonies} \times \text{dilution factor} \times 50}{\text{Sample collection volume (g)}}$$

Dilution factor: Dilution factor by 10 times dilution method

B. Method 2

Add 20 mL each of test agar medium in advance, and apply by coating 0.1 mL each of sample solution on five petri dishes being solidified. Count the colonies that appeared in the culture period specified in the monographs at the temperature as specified in the monographs, and determine the average number of the colonies.

Number of viable bacteria in 1 g of sample

$$= \frac{\text{Average number of colonies} \times \text{dilution factor} \times 500}{\text{Sample collection volume (g)}}$$

Dilution factor: Dilution factor by 10 times dilution method

(20) Infrared Spectrophotometry

Infrared Spectrophotometry is a method of measurement of the extent, at various wave numbers, of absorption of infrared radiation when it passes through a layer of a substance. In the graphic representation of infrared spectra, the plot usually shows units of wave numbers as the abscissa and units of transmittance or absorbance as the ordinate. Since the wave number and the respective intensity of an absorption maximum depend on the chemical structure of a substance, this measurement can be used to identify or determine a substance.

Apparatus:

Double beam-type infrared spectrophotometers are available.

Adjust the instruments according to the instruction manual of each individual instrument, proceed the measurement. A liner relation of the transmittance should be between 20 % and 80 % within 1 % in deviation, the repeatability of transmittance should be within ± 0.5 % by measuring twice repeatedly, and the reproducibility of wave number should be within ± 5 cm^{-1} at about 3,000 cm^{-1} , within ± 1 cm^{-1} at about 1,000 cm^{-1} . Correct the wavenumber scale by using absorption band of 3,060 cm^{-1} , 1,601 cm^{-1} , 1,029 cm^{-1} , and 907 cm^{-1} etc., of polystyrene films.

Procedure:

Prepare the specimen for the measurement according to one of the following procedures so that the transmittance of most of the absorption bands is in the range of 20 % to 80 %. Single crystals of sodium chloride, potassium bromide, thallium bromo-iodide etc. are available for the optical plate.

A. Potassium bromide disk method

Powder 1 to 2 mg of solid sample in an agate mortar, titrate rapidly 100 to 200 mg of potassium bromide for infrared spectrophotometry with precautions against moisture absorption, place in a suitable die (disk-forming container), press the mixture under reduced pressure not exceeding 0.67 kPa in a die with pressure applied to the die of 5,000 to 10,000 kg per cm² for 5 to 8 minutes, and examine its absorption spectrum.

B. Solution method

Place the sample solution prepared by the method directed in each monograph in a fixed cell for liquid, and usually measure the spectrum by placing the solvent used for preparing the sample solution in the reference beam. The thickness of the fixed cell is usually 0.1 mm or 0.5 mm.

C. Paste method

Powder a solid specimen in an agate mortar, titrate the specimen with liquid paraffin to give a homogeneous paste, place the plate upon another optical plate with precautions against intrusion of air, bubbles in the film, and examine its absorption spectrum.

D. Liquid film method

Examine 1 to 2 drops of a liquid specimen as a thin film held between two optical plates. When the absorption intensity is not sufficient, place spacers of aluminum foil, etc., between the two optical plates to make a thicker liquid film.

E. Film method

Examine a thin film just as it is or a prepared thin film as directed in each monograph.

F. Gas sampling method

Put a sample gas in a gas cell previously evacuated under the pressure directed in the monograph, and examine its absorption spectrum. The path length of the gas cell is usually 5 to 10 cm, but, if necessary, may exceed 1 m.

G. ATR method

Place a specimen in close contact with an attenuated total reflectance (ATR) prism, and examine its reflectance spectrum.

(21) Optical Rotation Determination

Optical rotation determination is a method to measure a degree of rotation of polarized plane by the polarimeter when a polarized light passes through the optically active substance or its solution

The optical rotation α_x^t means optical rotation when it is measured at t °C by using specific monochromatic light x (expressed by wavelength of light or the specific beam name), dextrorotatory is expressed by placing plus sign (+), levorotatory is expressed by placing minus sign (-) before the figure of the angular rotation.

Specific optical rotation $[\alpha]_x^t$ is calculated by the following equation.

$$[\alpha]_x^t = \frac{100\alpha}{lc}$$

t: The temperature (°C) of measurement

x: The wavelength (nm) of the specific monochromatic light. (In the case of the D line, it is describe as D.)

α : The angle, in degrees, of rotation of the plane of the polarized light.

l: The thickness of the layer of sample solution, i.e., the length of the polarimeter tube (mm).

c: Sample concentration in g/mL. When an intact liquid sample is used for the direct measurement without dilution by an appropriate solvent, c equals to its density (g/mL).

However, unless otherwise specified, the specific gravity may be used instead of the density.

Procedure:

Unless otherwise specified, the measurement is generally performed at 20 °C, using a 100 mm tube, and D line of sodium lamp as the light source.

(22) Crude Fat Determination

Crude fat determination is a method by quantifying ether soluble substance of fat or others in sample.

In the monographs, for example, to specify as "20.0 % or less (2 g)," means to indicate that the weight is 200 mg or less per 1 g of this product when weighing up to digit 0.001 g of 2 g of this product, recording the number, and quantifying the crude fat by the procedure as follows.

Procedure

Except otherwise specified, perform by the following method.

Weigh up to digit 0.01 g of 2~5 g of sample, record the number, place in a thimble filter of about 2.2cm diameter and about 9cm height, and fill cotton wool by lightly pressing in several small portions on it. After drying for 2 hours in a dryer at 95~100 °C and cool in a desiccator (silica gel), place in a soxhlet fat extraction apparatus which is connected to a fat weighing bottle (dried at 95~100 °C in advance, and after being cooled in a desiccator, the weight was measured.), and extract with ether. After extraction for 16 hours, collect the ether in fatty weighing bottle by removing the thimble.

After evaporating the rest of ether by removing the fat weighing bottle, dry for 3 hours at 95~100 °C, and cool in a desiccator, then weigh up to digit 0.01 g of the mass to record the number.

(23) Crude Fiber Determination

Crude fiber determination is a method by quantifying components of cellulose, other insoluble, or slightly soluble by sequentially processing sample with sulfate of 1.25 % and sodium hydroxide solution of 1.25 %.

In the monographs, for example, to specify as "5.0 % or less (2 g)" means to indicate that the weight is 50 mg or less per 1 g of this product when weighing up to digit 0.001 g of 2 g of this product, record the number, and quantifying crude fiber by the procedure as follows.

Procedure

Except otherwise specified, perform by the following method.

Weigh up to digit 0.001 g of 2~5 g of sample to record the number, place in a tall beaker of 500 mL, add 50 mL of 5 % sulfuric acid solution, further, create 200 mL by adding water, and mark the line on outer wall of the tall beaker along the liquid surface allowed to stand. Next, cover the tall beaker with a watch glass or a condenser, and boil vigorously for 30 minutes. Moisture evaporated during that time keeps the concentration of sulfuric acid to be 1.25 % by supplying hot water at all times.

After 30 minutes, wash with hot water until no acidic exists by filtering acid insoluble substance with stainless screen of 0.044 mm (shaker No. 325 or equivalent to this). Transfer the acid insoluble substance to the original tall beaker by using 130~140 mL of water, add 50 mL of 5 % sodium hydroxide solution, create 200 mL by adding water to the marked line, and after vigorously boiling for 30 minutes by covering with the condenser or the watch glass, filter by filter paper (previously, which was placed in a weighing dish, dried for 2 hours at 135 ± 2 °C, cooled in a desiccator (silica gel), and the mass was measured), wash the filtrate with hot water until no alkaline exists, and after washing 3~4 times each in the order of alcohol and ether, air-dry for 3~4 hours.

Next, transfer acid and alkali insoluble substance to the original weighing dish along with the filter paper, dry for 2 hours at 135 ± 2 °C, cool in the desiccator, and weigh up to digit 0.001 g of the mass to record the number.

Thereafter, place in a crucible (previously, which was ignited, cooled in the desiccator, and the mass was measured), and after carbonizing by heating gently for 2 hours, make ash at 550~600 °C, cool in the desiccator, and obtain the amount of crude ash by weighing up to digit 0.001 g of the mass. Subtract the amount of the crude ash from the amount of acid - alkali insoluble, and determine as the amount of crude fiber.

(24) Nitrogen Determination

Nitrogen Determination is a method to determine the ammonia in an organic substance in which the nitrogen is converted into ammonium sulfate by decomposition of the organic substance with sulfuric acid.

The description of, for example, "5.0~7.0 % (Kjeldahl Method)" in the monograph, indicate that the quantity of nitrogen is 50~70 mg per 1 g of this product when the test is performed in the following manner: weigh a quantity of the sample corresponding to about 20 to 30 mg of nitrogen to three significant digits, record the value, and determining nitrogen in the following Kjeldahl Method.

Kjeldahl Method

Apparatus:

Use hard glass apparatus as illustrated in figure. It is thoroughly constructed of hard glass, and ground glass surfaces may be used for joints. All rubber parts used in the apparatus should be boiled for 10 to 30 minutes in 1 mol/L sodium hydroxide test solution and for 30 to 60 minutes in water, and finally after washed thoroughly with water before use.

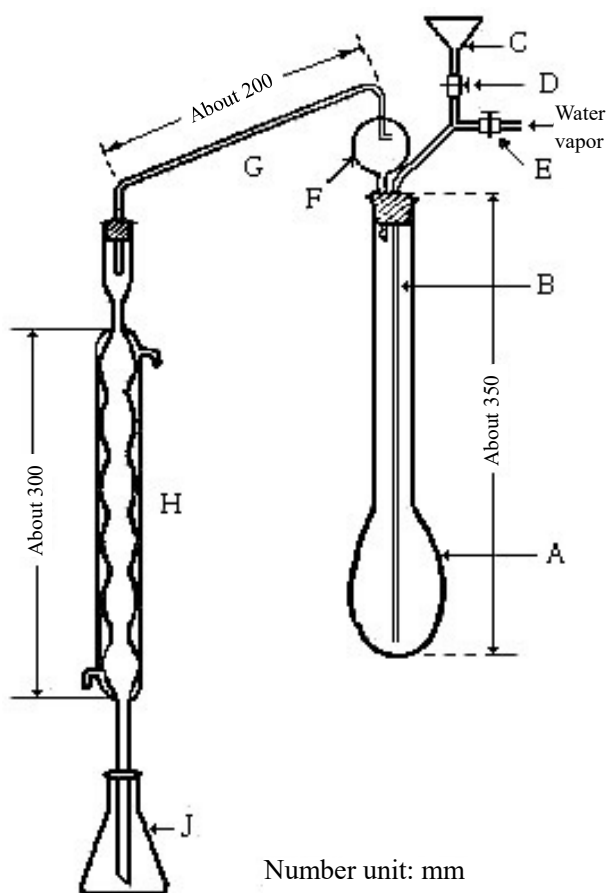

A: Kjeldahl flask

B: Glass tube

C: Funnel for addition of alkali solution

D and E: Rubber tubing with a clamp

F: Spray trap

G: Distilling tube

H: Condenser tube

J: Absorption flask

Procedure:

Unless otherwise specified, proceed by the following method.

Weigh a quantity of the sample corresponding to 20 to 30 mg of nitrogen (N) to three significant digits, record the value, and place in the Kjeldahl flask A. Add 5 g (4.5~5.4 g) of potassium sulfate powder, 0.5 g (0.45~0.54 g) of copper (II) sulfate, and 20 mL of sulfuric acid. Incline the flask at about 45°, heat gently until effervescence ceases, raise the temperature to boil, the solution changes a blue and clear, and heat again for 1 to 2 hours.

After cooling, add gradually sufficient water, cool the solution, and connect the flask to the distillation apparatus washed beforehand by passing steam through it.

To the absorption J add 20 mL of boric acid solution (1 → 25), 3 drops of bromocresol green-methyl red test solution add sufficient water to immerse the lower end of the condenser tube H. Add 85 mL of sodium hydroxide solution (2 → 5) in small portions through the funnel C, rinse the funnel with a small quantity of water, close the clamp attached to the rubber tubing D, shake the Kjeldahl flask gently and mix the solution, then begin the distillation with steam, and continue until the distillate measures about 120 mL. Remove the absorption flask from the lower end of the condenser tube H, continue the distillation for a while, rinsing the end part of the condenser tube with a small quantity of water, and titrate the distillate with 0.05 mol/L sulfuric acid until the color of the solution changes from green through pale grayish blue to pale grayish red-purple.

Perform a blank determination in the same manner, and make any necessary correction.

0.05 mol/1ml of L Sulfuric acid = 1.401 mg N

Semimicro-Kjeldahl Method

Apparatus:

Use the apparatus illustrated in figure. It is thoroughly constructed of hard glass, and ground glass surfaces may be used for joints. All rubber parts used in the apparatus should be boiled for 10~30 minutes in 1 mol/L sodium hydroxide test solution and for 30~60 minutes in water, and finally washed thoroughly with water before use.

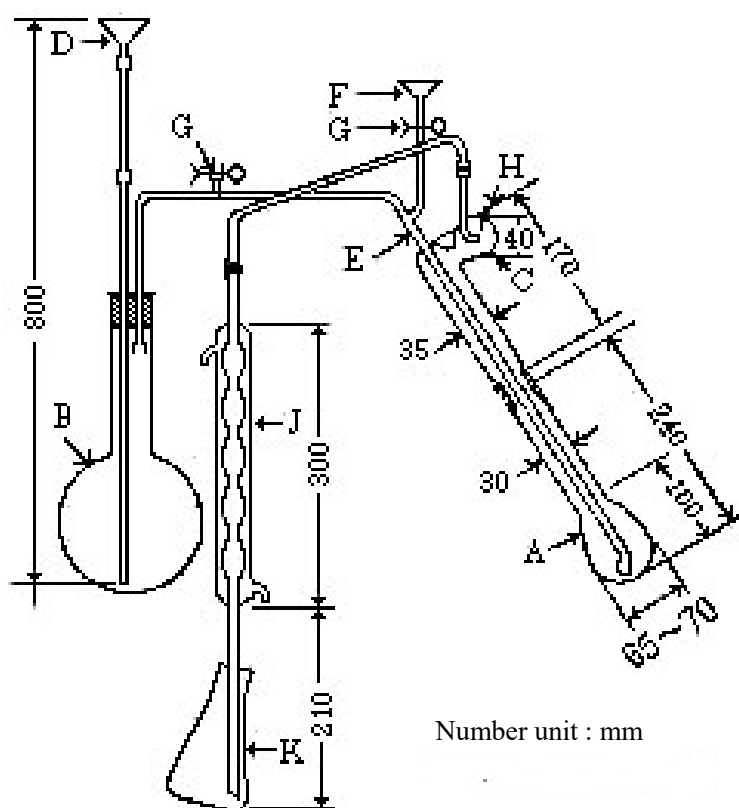

- A: Kjeldahl flask
- B: Steam generator, containing water, to which 2~3 drops of sulfuric acid and fragments of boiling chips for preventing bumping have been added.
- C: Spray stop
- D: Water supply funnel
- E: Steam tube
- F: Funnel for addition of alkali solution to flask A
- G: Rubber tubing with a clamp
- H: A small hole having a diameter approximately equal to that of the delivery tube
- J: Condenser, the lower end of which is cut beveled.
- K: Absorption flask

Procedure:

Unless otherwise specified, proceed by the following method.

Weigh or pipet a quantity of the sample corresponding to 2~3 mg of nitrogen (N: 14.01) to three significant digits, record the value, or measure with transfer pipet, and place in the Kjeldahl flask A. Separately, mix and powder 10 g (9.5~10.4 g) of potassium sulfate and 1 g (0.5~1.4 g) of copper sulfate, add 1 g (0.5~1.4 g) of this powder to the flask, wash down any adhering sample from the neck of the flask with a small quantity of water, further. Add 7 mL of sulfuric acid, allowing it to flow down the inside wall of the flask.

Then, while shaking the flask, add cautiously 1 mL of strong hydrogen peroxide water drop by drop along the inside wall of the flask. Heat the flask until the solution changes through a blue and clear, and the inside of the flask is free from carbonaceous material. If necessary, add a small quantity of strong hydrogen peroxide water after cooling, and heat again. After cooling, add cautiously 20 mL of water, cool the solution.

Connect the flask to the distillation apparatus washed beforehand by passing steam through it. To the absorption flask add 15 mL of boric acid solution (1 → 25), 3 drops of bromocresol green-methyl red test solution and add sufficient water to immerse the lower end of the condenser tube J. Add 30 mL of sodium hydroxide solution (2 → 5) through the funnel F, rinse cautiously the funnel with 10 mL of water, close the clamp attached to the rubber tubing G within 30 seconds, then begin the distillation with steam, and continue until the distillate measures 80~100 mL. Remove the absorption flask from the lower end of the condenser J, rinsing the end part with a small quantity of water, and titrate the distillate with 0.005 mol/L sulfuric acid until the color of the solution changes from green through pale grayish blue to pale greyish red-purple.

Perform a blank determination in the same manner, and make any necessary correction.

0.005 mol/L sulfuric acid = 0.1401 mg N

(25) Qualitative Tests

Qualitative Tests are applied to the identification of the sample and done generally with quantities 2 to 5 mL of the test solution.

Zinc Salt:

- A. Neutral to alkaline solutions of zinc salts yield a whitish precipitation with ammonium sulfide test solution or sodium sulfide test solution. The separated precipitation does not dissolve in dilute acetic acid but dissolves upon subsequent addition of dilute hydrochloric acid.
- B. Solutions of zinc salts yield a white precipitation with potassium hexacyanoferrate (II) test solution. When dilute hydrochloric acid is added to a portion of the suspension, the precipitate does not dissolve. When 1 mol/L sodium hydroxide test solution is added to another portion, the precipitate dissolves.
- C. Acidic solutions of zinc salts with phosphoric acid yield a pale purple precipitation, when 1 drop of copper (II) sulfate solution (1 → 1000) and 2 mL of mercury (II) ammonium thiocyanate test solution are added.

Aluminum Salt:

- A. Solutions of aluminum salts, when treated with ammonium chloride test solution and ammonia test solution, yield a gelatinous, white precipitate which does not dissolve in an excess of ammonia test solution.
- B. Solutions of aluminum salts, when treated with 1 mol/L sodium hydroxide test solution, yield a gelatinous, white precipitate which dissolves in an excess of the reagent.
- C. Solutions of aluminum salts, when treated with sodium sulfide test solution, yield a gelatinous, white precipitate which dissolves in an excess of the reagent.
- D. Add ammonia test solution to solutions of aluminum salts until with a gelatinous, white precipitate is produced. The color of the precipitate changes to red upon addition of 5 drops of alizarin red S test solution.

Ammonium Salt:

When heated with an excess of 1 mol/L sodium hydroxide test solution, ammonium salts evolve the odor of ammonia. This gas changes moistened red litmus paper into blue.

Chloride:

- A. Solutions of chlorides evolves an odor of chlorine, when mixed with sulfuric acid and potassium permanganate, and heated. The gas evolved turns moistened potassium iodide starch paper blue.
- B. Solutions of chlorides yield a white precipitate with silver nitrate test solution. When dilute nitric acid is added to a portion of the separated precipitate, it does not dissolve. When an excess of ammonia test solution is added to another portion, the precipitate dissolves.

Potassium Salt:

- A. When the Flame Coloration Test is applied to potassium salts, a pale purple color develops. When it gives a yellow color, a red–purple color can be seen through cobalt glass.
- B. Neutral solutions of potassium salt yield a white crystalline precipitate with sodium hydrogen tartarate test solution. The formation of the precipitate is accelerated by rubbing the inside wall of test tube with a glass rod. The separated precipitate dissolves upon addition of any of ammonia test solution, 1 mol/L sodium hydroxide test solution or sodium carbonate test solution.
- C. Acidic solutions of potassium salts in acetic acid yield a yellow precipitate with sodium hexanitrocobaltate (III) test solution.
- D. Potassium salts do not evolve the odor of ammonia, when an excess of 1 mol/L sodium hydroxide test solution is added and warmed (discrimination from ammonium salts).

Calcium Salt:

- A. When the Flame Coloration Test is applied to calcium salt, a yellow-red color develops.

- B. Solutions of calcium salts yield a white precipitate with ammonium carbonate test solution.
- C. Solutions of calcium salts yield a white precipitate with ammonium oxalate test solution. The separated precipitate does not dissolve in dilute acetic acid, but dissolves in dilute hydrochloric acid.
- D. Neutral solutions of calcium salts produces no precipitate, when mixed with 10 drops of potassium chromate test solution and heated (discrimination from strontium salts).

Citrate:

- A. Solutions of citrate yield a white precipitate with potassium permanganate test solution when an excess of mercury (II) sulfate is added and boiled. The separated precipitate dissolves in sodium chloride test solution.
- B. Neutral solutions of citrates, when mixed with an equal volume of dilute sulfuric acid and two-thirds volume of potassium permanganate test solution, heated until the color of permanganate is discharged, and then treated dropwise with bromine test solution to one-tenth of the total volume, yield a white precipitate.
- C. Neutral solutions of citrates, when boiled with an excess of calcium chloride test solution, yield a white crystalline precipitate. When 1 mol/L sodium hydroxide test solution is added to a portion of the separated precipitate, it does not dissolve. When dilute hydrochloric acid is added to another portion, the precipitate dissolves.

Succinate:

Solutions of succinate adjusted to pH 6 to 7 yield a brown precipitate when 1 mL of iron (III) chloride is added.

Acetate:

- A. When warmed with sulfuric acid (1 → 2), acetates evolves the odor of acetic acid.
- B. When an acetate is warmed with sulfuric acid and a small quantity of ethanol, the odor of ethyl acetate is evolved.
- C. Neutral solutions of acetate produces a red-brown color with iron (III) chloride test solution, and a red-brown precipitate when boiled. The precipitate dissolves and the color of the solution turns changes to yellow upon addition of hydrochloric acid.

Tartrate:

- A. Neutral tartrate solutions yield a white precipitate with silver nitrate test solution. When nitric acid is added to a portion of the separated precipitate, it dissolves. When ammonia test solution is added to another portion and warmed, the precipitate dissolves and metallic silver is deposited gradually on the inside wall of the test tube, forming a mirror.

- B. Solutions of tartrates exhibit a red-purple to purple color, when 2 drops of acetic acid, 1 drop of iron (II) sulfate test solution, 2 to 3 drops of hydrogen peroxide test solution and an excess of 1 mol/L sodium hydroxide test solution are added.
- C. When a solution, prepared by mixing 2 to 3 drops of a solution of resorcinol (1 → 50) and 2 to 3 drops of a solution of potassium bromide (1 → 10) with 5 mL of sulfuric acid, is added to 2 to 3 drops of solutions of tartrates, and then heated for 5 to 10 minutes on a water bath, a deep blue color is produced. The solution exhibits a red color when poured to an excess of water after cooling.

Nitrate:

- A. Solutions of nitrates, when mixed with an equal volume of sulfuric acid, the mixture is cooled, and iron (II) sulfate test solution is superimposed, a dark-brown ring is produced at the junction of the two liquids.
- B. Solutions of nitrates exhibits a blue color with diphenylamine test solution.
- C. When potassium permanganate test solution is added to acidic solutions of nitrate in sulfuric acid, the red-purple color of the reagent does not fade (discrimination from nitrite).

Carbonate:

- A. Carbonates effervesce upon addition of dilute hydrochloric acid, generating a gas, which produces a white precipitate within 30 seconds, when passed into calcium hydroxide test solution (common with bicarbonate).
- B. Solutions of carbonates yield with magnesium sulfate test solution a white precipitate, which dissolves by addition of dilute acetic acid.
- C. Cold solutions of carbonates exhibits a red color with 1 drop of phenolphthalein test solution (discrimination from bicarbonates).

Bicarbonate:

- A. Bicarbonates effervesce upon addition of dilute hydrochloric acid, generating a gas, which produces a white precipitate within 30 seconds, when passed into calcium hydroxide test solution (common with carbonate).
- B. Solutions of bicarbonates produce no precipitate with magnesium sulfate test solution, but produce a white precipitate when boiled subsequently.
- C. Cold solutions of bicarbonates remain unchanged or exhibits only a slightly red color upon addition of 1 drop of phenolphthalein test solution (discrimination from carbonates).

Ferrous Salt:

- A. Slightly acidic solutions of ferrous salt yield with potassium hexacyanoferrate (III) test solution a blue precipitate, which does not dissolve in dilute hydrochloric acid subsequently added.

- B. Solutions of ferrous salts yield with 1 mol/L sodium hydroxide test solution a greenish gray, gelatinous precipitate, which changes to black with sodium sulfide test solution. The separated precipitate, dissolves in dilute hydrochloric acid.
- C. Neutral or slightly acidic solutions of ferrous salts exhibit an intense red color upon dropwise addition of *o*-phenanthroline in ethanol (1 → 50).

Ferric Salt:

- A. Slightly acidic solutions of ferric salts yield with potassium hexacyanoferrate (II) test solution a blue precipitate, which does not dissolve in dilute hydrochloric acid subsequently added.
- B. Solutions of ferric salts yield with 1 mol/L sodium hydroxide test solution a gelatinous, red-brown precipitate, which changes to black upon addition of sodium sulfide test solution. The separated precipitate dissolves in dilute hydrochloric acid, yielding a white turbidity.
- C. Neutral or slightly acidic solutions of ferric salts exhibits red color upon dropwise addition of ammonium thiocyanate. When hydrochloric acid is added to this mixture, the color does not disappear, which disappears in mercury (II) chloride solution subsequently added.

Cupric Salt:

- A. When a well-polished iron plate is immersed in acidic solution of cupric salts in hydrochloric acid, a red metallic film appears on its surface.
- B. Solutions of cupric salts produce a pale blue precipitate with a small quantity of ammonia test solution. The precipitate dissolves in an excess of the reagent, yielding a deep bluecolored solution.
- C. Solutions of cupric salts yield a red-brown precipitate with potassium hexacyanoferrate (II) test solution. When dilute nitric acid is added to a portion of the suspension, the precipitate does not dissolve. When ammonia test solution is added to another portion, the precipitate dissolves, yielding a deep bluecolored solution.
- D. Solutions of cupric salts produce a black precipitate with sodium sulfide test solution. When dilute hydrochloric acid, dilute sulfuric acid or 1 mol/L sodium hydroxide test solution is added to a portion of the separated precipitate, it does not dissolve. When hot dilute nitric acid or potassium cyanide test solution is added to another portion, the precipitate dissolves.

Sodium Salt:

- A. When the Flame Coloration Test is applied to sodium salts, a yellow color develops.
- B. Concentrated, neutral or slightly alkaline solutions sodium salts yield a white, crystalline precipitate with potassium pyroantimonate test solution. The formation of the precipitate is accelerated by rubbing the inside wall of the test tube with a glass rod.

Lactate:

Acidic solutions of lactate in sulfuric acid, when heated with potassium permanganate test solution, evolve the odor of acetaldehyde.

Aromatic amines, primary

Acidic solutions of primary aromatic amines, when cooled in ice, mixed with 3 drops of sodium nitrite test solution under agitation, allow to stand for 2 minutes, mixed well with 1 mL of ammonium sulfamate test solution, allow to stand for 1 minute, and then mixed with 1 mL of *N*-(1-naphthyl)-*N'*-diethylethylenediamine oxalate test solution, exhibit red-purple color.

Magnesium Salt:

- A. Solutions of magnesium salts with ammonium carbonate test solution yield a white precipitate, which dissolves in ammonium chloride test solution. A white, crystalline precipitate is reproduced by subsequent addition of sodium hydrogen phosphate test solution.
- B. Solutions of magnesium salts yield with 1 mol/L sodium hydroxide test solution a white, gelatinous precipitate. When excess 1 mol/L sodium hydroxide test solution is added to one portion of the suspension, the precipitate does not dissolve. When iodine test solution is added to another portion, the precipitate develops a dark-brown color.

Manganese Salt:

- A. Solutions of manganese salt yield a white precipitate with ammonia test solution. When silver nitrate test solution is added to a portion of suspension, the precipitate changes to black. When another portion is allowed to stand, the upper part of the precipitate exhibits a brownish color.
- B. Acidic solutions of manganese salts in dilute nitric acid exhibit a red-purple color with a small quantity of powdered bismuth sodium trioxide.

Iodide:

- A. Solutions of iodides yield a yellow precipitate with silver nitrate test solution. When dilute nitric acid is added to one portion of the suspension, and strong ammonia water to another portion, the precipitates do not dissolve in either of these reagents.
- B. Acidic solutions of iodides exhibit a yellow-brown color with 1 to 2 drops of sodium nitrite test solution and then yield a black-purple precipitate. The solutions exhibit a deep blue color with starch test solution subsequently added.

Sulfate:

- A. Solutions of sulfates yield with barium chloride test solution a white precipitate, which does not dissolve upon addition of dilute nitric acid.
- B. Neutral solution of sulfates yield with lead (II) acetate test solution a white precipitate, which dissolves upon subsequent addition of ammonium acetate test solution.

C. When an equal volume of dilute hydrochloric acid is added, solutions of sulfates yield no white turbidity (discrimination from thiosulfates), and do not evolve the odor of sulfur dioxide (discrimination from sulfites).

Phosphate (Positive Phosphate):

- A. Neutral solutions of phosphates yield with silver nitrate test solution a yellow precipitate, which dissolves upon addition of dilute nitric acid or ammonia test solution.
- B. Acidic solutions in dilute nitric acid of phosphates yield a yellow precipitate with ammonium molybdate test solution on warming. The precipitate dissolves upon subsequent addition of 1 mol/L sodium hydroxide test solution or ammonia test solution.
- C. Neutral or ammonia-alkaline solutions of phosphates yield with magnesia test solution a white, crystalline precipitate, which dissolves upon subsequent addition of diluted hydrochloric acid.

(26) Lead Limit Test

Lead Limit Test is a limit test for lead contained in samples.

A. Dithizone Method

Reagents · Test solutions:

Ammonium citrate solution: Dissolve 45 g (44.5~45.4 g) of ammonium citrate in water to make 100 mL.

Sodium sulfite solution: Dissolve 15 g (14.5~15.4 g) of sodium sulfite in water to make 100 mL. Prepare before use.

Potassium cyanide solution: Dissolve 10 g (9.5~10.4 g) of potassium cyanide in water to make 100 mL.

Dilute potassium cyanide solution: To 10 mL of potassium cyanide solution add water to make 100 mL. Prepare before use.

Dithizone-benzene solution: Dissolve 0.05 g (0.045~0.054 g) of trituated dithizone in 100 mL of chloroform, transfer to a separator, and extract with 3 portions of 100 mL of strong ammonia water (1 → 100). Combine the ammonia water extracts, and wash with 3 portions of 200 mL of benzene. To the water layer add dilute hydrochloric acid to make slightly acidic, extract 2 portions of 200 mL of benzene. Combine the benzene extracts, add benzene to make about 1,000 mL, and use this solution as the stock solution. Dilute the stock solution with benzene and prepare 10 times diluted solution, and use this solution as the sample solution. Determine the absorbance A of the sample solution at the wavelength of maximum absorption at about 620 nm around and in a layer of 10 mm in length, using benzene as the blank. Measure $20,000/(70.6 \times A)$ mL of the stock solution, transfer to a 1,000 mL

volumetric flask, and add benzene to make exactly 1,000 mL. 1,000 mL of this solution contains 20 mg of dithizone ($C_{13}H_{12}N_4S$). Prepare before use.

Lead standard solution for dithizone: Measure 10 mL of lead standard solution with transfer pipet, transfer to a 100 mL of volumetric flask, add nitric acid (1 → 100) to make exactly 100 mL. 1 mL of this solution contains 0.001 mg of lead (Pb). Prepare before use.

Procedure:

Measure the amount specified in individual monograph of the sample solution and the blank solution obtained in the same manner as for the sample solution, add 2 mL of ammonium citrate solution and 2 drops of methyl red test solution, add strong ammonia water dropwise until the solution exhibits a yellow color, and add water to make 100 mL. To this solution add 10 mL of potassium cyanide solution and 10 mL of sodium sulfite solution, shake well, and heat the mixture on a water bath for 10 to 15 minutes. Cool, add 1.5 mL of strong ammonia water, transfer to a separator, add 10 mL of dithizone-benzene solution with transfer pipet, shake vigorously for 1 minute, and remove the water layer. Add 40 mL of dilute potassium cyanide solution, shake vigorously for 30 seconds, allow to stand, and separate the benzene layer, and determine the absorbance A_T and A_B of this solution at the wavelengths of maximum absorption at about 525 nm in a layer of 10 mm in length, using benzene as the blank. Determine the absorbance A_S and A_0 of 10 mL of lead standard solution for dithizone and 10 mL of water in the same manner as for the sample solution.

Amount ($\mu\text{g/g}$) of lead (Pb) =

$$10 \times \frac{A_T - A_B}{A_S - A_0} \times \frac{\text{Total volume of the sample solution (mL)}}{\text{Volume of the sample solution taken (mL)}} \times \frac{1}{\text{Mass of the sample (g)}}$$

Note: Reagent and test solutions used in the test should contain little or no lead. Use the glassware which has been washed well with hydrochloric acid (1 → 2) and then with water.

B. Atomic Absorption Spectrophotometry

Procedure:

(a) Method 1

Preparation of sample solutions and standard solutions:

Unless otherwise specified, sample solutions are prepared as follows.

Place the amount of sample specified in the monograph in a crucible of platinum or quartz, moisten with a small amount of sulfuric acid, then heat gently at a temperature as low as practicable until the sample is almost incinerated, cool, add 1 mL of sulfuric acid, and heat gently and ignite at 450–550 °C until the sample is completely incinerated. Dissolve the residue in a small quantity of nitric acid (1 → 150), transfer to a 10 mL volumetric flask, and add nitric acid (1 → 150) to make exactly 10 mL, then use this solution as the sample solution. Unless otherwise specified, measure 1.0 mL of lead standard solution with transfer pipet, transfer to a

10 mL volumetric flask, add nitric acid (1 → 150) to make exactly 10 mL, then use as the standard solution.

Test:

Unless otherwise specified, determine the absorbance of standard solutions and sample solutions according to Atomic Absorption Spectrophotometry (frame type) under the following conditions: the absorbance of the sample solution should be not more than that of the standard solution.

Operating Conditions:

Lamp: Lead hollow-cathode lamp

Wavelength: 283.3 nm

Supporting gas: Air

Combustible gas: Acetylene

(b) Method 2

Preparation of sample solutions:

Unless otherwise specified, sample solutions are prepared as follows.

Weigh the amount of sample specified in the monograph, place in a polytetrafluoroethylene digestion vessel, dissolve the sample in 0.5 mL of nitric acid, close it hermetically, and heat at 150 °C for 5 hours. Cool, transfer to a 5 mL volumetric flask, and add water to make exactly 5 mL, use this solution as the sample solution.

Test:

Unless otherwise specified, proceed as follows.

Prepare not less than 3 sample solutions, proceed the test according to standard addition method of Atomic Absorption Spectrophotometry (Frameless type (Electrothermal type)) under the following conditions. The standard solution is prepared by adding water to an appropriate amount of lead standard solution measured with transfer pipet. To the solution for measurement add an equal volume of paradium (II) nitrate test solution, mix well. Measure 10 mL of nitric acid with transfer pipet, transfer to a 100 mL volumetric flask, add water to make exactly 100 mL, and perform a blank determination using this solution, make any necessary correction.

Operating Conditions:

Lamp: Lead hollow-cathode lamp

Wavelength: 283.3 nm

Drying temperature: 110 °C

Incineration temperature: 600 °C

Temperature of sample atomizer: 2,100 °C

(27) Bio Autograph Method

Bioautograph method is a method biologically by determining or confirming approximate amount of components with a titer in mixture being separated by applying filter paper chromatography or thin layer chromatography.

Procedure

Filter paper, thin-layer plate, culturing box shape, developing solvent, working standard dilutions, sample solution, medium, preparation for test bacteria solution (or test spore solution), R_f value, travel distance, measurements, calculation, and evaluation are specified in the monographs.

Create flat plate by adding medium and test bacteria solution (or test spore solution) to sterilized culturing box. These procedures are performed in a sterile manner as possible.

Divide original line of filter paper or thin-layer plate into 4 equal portions at regular intervals, and draw a vertical line to have 4 compartments. Specify the center of original line of each section as the origin, drip 5 µL each of high concentration of working standard dilution to the origin from the 1st compartment to 3rd compartment in turn, and 5 µL of sample solution to the origin of the 4th compartment by using a micropipette, then after soaking, air-dry.

If necessary, after leaving the filter paper or the thin layer plate for 30~60 minutes in a device which is saturated with the gas of the developing solvent, raise or lower the development solvent. The temperature is set at 20~30 °C. When the underline or the upperline of the solvent reaches 10~30 mm from the upper end or the lower end of the filter paper or the thin-layer plate, stop the development, remove the thin layer plate or the filter paper, leave at room temperature, and remove the solvent by drying. After drying, divide the thin layer plate or the filter paper into 4 equal parts along the section line. If necessary, discard the unnecessary portion, and line up the filter paper or the thin-layer plate of 4 sections with the distance of about 15 mm each on the medium of the culturing box. In this case, carefully line up the medium and each section of the filter paper or the thin-layer plate in order to adhere completely. After contacting for 5~15 minutes, remove the filter paper or the thin layer plate. These procedures are performed with caution so that the bacteria do not enters. Culture for 17~20 hours at 32~37 °C in the culturing box.

(28) Thin Layer Chromatography

Thin layer chromatography is a method by using a thin layer made of suitable stationary phase and separating into each component by developing mixture with mobile phase, and is used for testing such as purity or confirmation of substance.

Preparation of thin-layer plate

Perform generally by the following method.

Suspend powder of stationary phase solid specified in the monographs in water by using suitable device on a glass plate having a uniform thickness in the smooth of 50 mm × 200 mm or 200 mm × 200mm, and coat to uniform with 0.2~0.3 mm thickness. After air-drying, heat for 30 to 60 minutes at a constant temperature between 105~120 °C, and prepare by drying. It is possible to use a suitable plastic plate instead of the glass plate. Store the thin-layer plate to avoid moisture.

Procedure

Except otherwise specified, perform by the following method.

Make a height of about 20 mm from the lower end of thin-layer plate as original line, release at least 10 mm from both sides, and air-dry by spotting sample solution and standard solution of the amount specified in the monographs at a distance of about 10 mm by using a micropipette on the original line. Then, place the thin layer plate in a container for development and seal, and perform development at room temperature. Place the development solvent in a depth of 10 mm of the container for development in advance, and saturate with vapor of the development solvent.

When raising the tip end of the development solvent to the distance specified in the monographs from the original line, remove the thin layer plate, and after air-drying, determine the color or the position of each spot by the specified method in the monographs. The R_f value is calculated by the following equation.

$$R_f = \frac{\text{Distance to a center of a spot from original line}}{\text{Distance to solvent front from original line}}$$

(29) pH Measurement Method

In order to measure pH, use a pH meter having glass electrode.

pH is a value which is defined by the following equation. This value is not what has significance physicochemical in the strict sense, but match hydrogen ion concentration in the aqueous solution of the sample with the values shown in common logarithm of the reciprocal.

$$pH = pH_S + \frac{E - E_S}{\alpha}$$

pH_S: pH value of pH standard solution

E: Electromotive force of battery that combines reference electrode and glass electrode in sample solution.

E_S: Electromotive force of battery that combines reference electrode and a glass electrode in pH standard solution.

$$\alpha = \frac{2.3026 \times RT}{F}$$

R: gas constant

T: absolute temperature

F: Faraday constant

Device

pH meter generally consists of typically a glass electrode, detection unit consisting of a reference electrode, and instructing unit indicating pH found. There are asymmetric potential adjustment knob and temperature compensation knob in the instruction unit. If there is no temperature compensation knob, it has temperature sensing unit for temperature compensation.

According to the following procedure regarding pH meter, when measuring the pH of the pH standard solution of optional one type repeatedly five times, use ± 0.05 or less of the reproducibility. Note that the detector should be washed well with water every time before measurement.

Procedure

Soak glass electrode in water for a few hours in advance. Turn the pH meter on, and use after more than five minutes. Wash the detector with water well, and wipe off the attached water gently with filter paper. Match the knob with the temperature of the pH standard solution if there is a knob for temperature compensation, soak the detector in pH standard solution close to the pH value of the sample solution, and after more than two minutes passed, adjust the pH indication to become pH of pH standard solution at that temperature. When adjusting at two points, operate in accordance with above typically by using pH standard solution close to the pH value of the sample solution and phosphate pH standard solution, then wash the detection unit thoroughly with water. After wiping the attached water gently with filter paper, immerse in the sample solution, and read the measurement.

(30) Determination of Specific Gravity

The specific gravity means the ratio of the mass of a sample specimen to that of an equal volume of standard substance.

The specific gravity, $d_{t'}^t$, means the ratio of the mass of the sample specimen at t' °C to that of an equal volume of water (H₂O) at t °C. Unless otherwise specified, the measurement is to be performed by Method 1 and method 2. When the specified value is accompanied with the term "about" in the monograph, Method 3 is available.

Procedure:

A. Method 1: Measurement method by using specific gravity bottle

A pycnometer is a glass vessel with a capacity of usually 10 mL to 100 mL, having a ground-glass stopper fitted with a thermometer, and a side inlet-tube with a marked line and a ground-glass cap. Weigh a pycnometer, previously cleaned and dried, to determine its mass W . Remove the stopper and the cap. Fill the pycnometer with the sample solution, keeping them at a slightly lower temperature by 1~3 °C than the specified temperature t' °C, and stopper them, taking care not to leave bubbles. Raise the temperature gradually, and when the thermometer shows the specified temperature, remove the portion of the sample solution above the marked line through the side tube, cap the side tube, and wipe the outside surface thoroughly. Measure the mass W_1 of the pycnometer filled with the sample solution. Perform the same procedure, using the same pycnometer containing water, and note the mass W_2 at the specified temperature t °C.

$$d_t^{t'} = \frac{W_1 - W}{W_2 - W}$$

B. Method 2: Measurement using a Sprengel-Ostwald pycnometer

Sprengel-Ostwald pycnometer is a glass vessel with a capacity of usually 1 mL to 10 mL. As shown in figure, both ends are thick-walled fine tubes (inside diameter: 1~1.5 mm, outer diameter: 3~4 mm), one of which, tube A, has a line C marked on it. Determine the mass of a pycnometer, W , previously clean and dried, by hanging it on the arm of a chemical balance with a platinum or aluminum wire D. Immerse the fine tube B in the sample solution, which is at a lower temperature by 3 to 5 °C than the specified temperature t' °C. Attach rubber tubing or a ground-glass tube to the end of A, and suck up the sample solution until the meniscus is above the marked line C, taking care to prevent bubble formation. Immerse the pycnometer in a water bath kept at the specified temperature t' °C for about 15 minutes, and then, by attaching a piece of filter paper to the end of B, adjust the level of the sample solution to the marked line C. Take the pycnometer out of the water bath, wipe thoroughly the outside surface and determine the mass W_1 . By use of the same pycnometer, perform the same procedure for the standard solution of water. Weigh the pycnometer containing water at the specified temperature t °C, and note the mass W_2 . Calculate the specific gravity $d_t^{t'}$, according to the equation described in method 1.

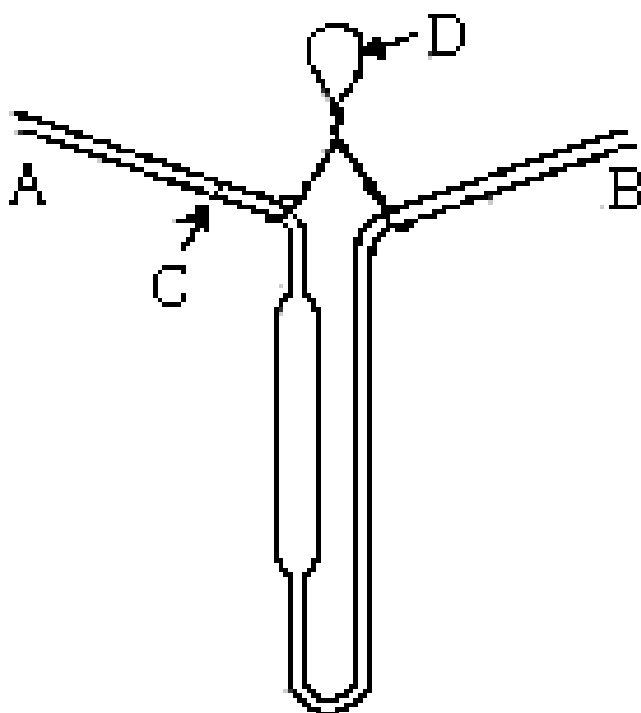

C. Method 3: Measurement using a hydrometer

Clean a hydrometer with ethanol or diethyl ether. Stir the sample well with a glass rod, and float the hydrometer in the well. When the temperature is adjusted to the specified temperature t' °C and the hydrometer comes to a standstill, read the specific gravity $d_4^{t'}$ at the upper brim of the meniscus. If specific instructions for reading the meniscus are supplied with the hydrometer, the reading must be in accordance with the instructions.

(31) Arsenic Limit Test

Arsenic Limit Test is a limit test for arsenic contained in samples. The limit is expressed in terms of arsenic trioxide (As_2O_3).

In each monograph, the permissible limit for arsenic trioxide (as As_2O_3) is described in terms of mg/kg in the parentheses.

Apparatus A:

Use the apparatus illustrated in Fig. 1.

G: Mercury (II) bromide paper (18 mm × 18 mm)

H and J: Rubber stoppers

K: Clip

L: Mark of 40 mL

Place glass wool F in the exit tube B up to about 30 mm in height, moisten the glass wool uniformly with a mixture of an equal volume of lead (II) acetate test solution and water, and apply gentle suction to the lower end to remove the excess of the mixture. Insert the tube vertically into the center of the rubber stopper H, and attach the tube to the generator bottle A so that the small perforation E in the lower end of B extends slightly below. At the upper end of B, attach the rubber stopper J to hold the tube C vertically. Make the lower end to the exit tube of C level with that of the rubber stopper J. Place mercury (II) bromide paper G between the fitting surface of C and D before use, fix C and D with the clip K.

Procedure:

Preparation of the test solution, unless otherwise specified, is proceeded as directed in the following.

A. Method 1

Weigh the amount of the sample directed in the monograph, add 5 mL of water, dissolve by warming if necessary, and designate this solution as the test solution.

B. Method 2

Weigh the amount of the sample directed in the monograph, add 5 mL of water, and add 1 mL of sulfuric acid except in the cases that the samples are inorganic acid. Add 10 mL of sulfurous acid solution, transfer to a small beaker, and evaporate the mixture on a water bath until it is free from sulfurous acid and is reduced to about 2 mL in volume. Dilute with water to make 5 mL, and designate it as the test solution.

C. Method 3

Weigh the amount of the sample directed in the monograph, and place it in a crucible of platinum, quartz or porcelain. Add 10 mL of a solution of magnesium nitrate hexahydrate in ethanol (1 → 50), ignite the ethanol, and heat gradually to incinerate. If carbonized material still remains by this procedure, moisten with a small quantity of nitric acid, and ignite again to incinerate. After cooling, add 3 mL of hydrochloric acid, heat on a water bath to dissolve the residue, and designate it as the test solution.

The tests for the test solution, unless otherwise specified, is proceeded as directed in following.

A. Methods using an apparatus A

Place the test solution in the generator bottle A, and if necessary, wash down the solution in the bottle with a small quantity of water. Add one drop of bromophenol blue test solution, and after neutralizing with ammonia test solution, strong ammonia solution, or dilute hydrochloric

acid, add 5 mL of hydrochloric acid (1 → 2) and 5 mL of potassium iodide test solution, and allow to stand for 2~3 minutes. Add 5 mL of acidic tin (II) chloride test solution and allow to stand for 10 minutes at room temperature. Then add water to make 40 mL, add 2 g (1.5~2.4 g) of arsenic-free zinc, and connect the rubber stopper H fitted with B and C with the generator bottle A within 30 seconds. Transfer 5 mL of the absorbing solution for hydrogen arsenic to the absorber tube D, insert the tip of C to the bottom of the absorber tube D, then immerse the generator bottle A up to shoulder in water maintained at 25 °C, and allow to stand for 1 hour. Disconnect the absorber tube, add pyridine to make 5 mL, if necessary, and observe the color of the absorption solution: the color produced is not more intense than the standard color. Carry out the preparation of the standard color at the same time.

B. Methods using an apparatus B

Place the solution in the generator bottle A, and if necessary, wash down the solution in the bottle with a small quantity of water. Add one drop of methyl orange test solution, and after neutralizing with ammonia test solution, strong ammonia solution or dilute hydrochloric acid, add 5 mL of hydrochloric acid (1 → 2) and 5 mL of potassium iodide test solution, and allow to stand for 2~3 minutes. Add 5 mL of acidic tin (II) chloride test solution and allow to stand for 10 minutes at room temperature. Then add water to make 40 mL, add 2 g (1.5~2.4 g) of arsenic-free zinc, and connect the rubber stopper H fitted with B, C, D and G with the generator bottle A within 30 seconds. Immerse the generator bottle A up to shoulder in water maintained at 25 °C, allow to stand for 1 hour, and observe the color of the mercury (II) bromide paper: the color produced is not more intense than the standard color. Carry out the preparation of the standard color at the same time.

Preparation of standard color:

Unless otherwise specified, preparation of standard color is proceeded as directed in the following.

Measure accurately 2 mL of standard arsenic solution in the generator bottle A. Add 5 mL of hydrochloric acid (1 → 2) and 5 mL of potassium iodide test solution, and allow to stand for 2~3 minutes. Add 5 mL of acidic tin (II) chloride test solution, allow to stand at room temperature for 10 minutes, and then proceed as directed above. The color produced corresponds to 0.002 mg of arsenic trioxide (As_2O_3) and used as the standard.

Preparation of standard solutions:

Unless otherwise specified, preparation of standard solutions is proceeded as directed in the following.

Standard arsenic stock solution: Weigh 100 mg (99.5~100.4 mg) of finely powdered arsenic trioxide dried at 105 °C for 4 hours, and add 5 mL of sodium hydroxide solution (1 → 5) to dissolve. Add dilute sulfuric acid to neutralize, transfer to a 1,000 mL of volumetric flask,

add further 10 mL of dilute sulfuric acid, and add freshly boiled and cooled water to make exactly 1,000 mL.

Standard arsenic solution: Measure 10 mL of standard arsenic stock solution with transfer pipet, transfer to a 1,000 mL volumetric flask, add 10 mL of dilute sulfuric acid, and add freshly boiled and cooled water to make exactly 1,000 mL. Each mL of this solution contains 0.001 mg of arsenic trioxide (As_2O_3). Prepare standard arsenic solution just before use, and preserve in a glass-stoppered bottle.

Note: Apparatus, reagents and test solutions used in the test should contain little or no arsenic. If necessary, perform a blank determination.

(32) Vitamin A Assay

Vitamin A assay is a method to determine vitamin A in crude material for preparation of vitamin A oil, that of vitamin A powder and other vitamin A in feed additives using the ultraviolet-visible spectrophotometry. When any substance that would interfere with assay, it is necessary to perform appropriate pretreatments. One Vitamin A Unit (equal to 1 vitamin A I.U.) is equivalent to 0.3 μg of vitamin A (all-trans vitamin A alcohol).

Reagents:

Isopropanol: Determine the absorbances (10 mm), using water as the control solution: not more than 0.05 at 300 nm, and not more than 0.01 at 320~350 nm. If necessary, purify by distillation.

Diethyl ether: Distill before use, and remove 10 % each of the first and last.

Procedure:

All proceeded should be carried out quickly and care should be taken as far as possible to avoid exposure to air and other oxidants by using light-resistant containers. Unless otherwise specified in the monographs, apply Method 1, but if the assay conditions required for Method 1 are not suitable, apply method 2.

A. Method 1

Weigh about 0.5 g of the sample to three decimal places, record the result, dissolve in isopropanol, transfer to a 250 mL volumetric flask, and add isopropanol to make exactly 250 mL. Dilute exactly this solution with isopropanol so that the absorbances becomes about 0.5 at 326 nm (10 mm), and use this solution as the sample solution. Determine the absorption spectrum to obtain the wavelength of the maximum absorption and the absorbances at 300 nm, 310 nm, 320 nm, 326 nm, 330 nm, 340 nm and 350 nm (10 mm). When the maximum absorption lies between 325 nm and 328 nm, and the ratios of each absorbance to the absorbance at 326 nm are within the range of ± 0.030 of the values of the table, the potency of vitamin A in units per g of the sample is calculated from the following equation.

$$d_t' = \frac{W_1 - W}{W_2 - W}$$

Units of Vitamin A in 1 g = $E_{1\text{cm}}^{1\%}(326 \text{ nm}) \times 1,900$

$$E_{1\text{cm}}^{1\%}(326 \text{ nm}) = \frac{A}{W} \times \frac{V}{100}$$

V: Total volume (mL) of the sample solution

W: Amount (g) of sample in V mL of the sample solution

Perform the following identification to confirm retinol palmitate and retinol acetate.

Weigh the amount containing 15,000 units of vitamin A in the sample, reference standard of retinol acetate for thin-layer chromatography and reference standard of retinol palmitate for thin-layer chromatography, dissolve in 5 mL of petroleum ether respectively, and use these solution as the sample solution and standard solutions. Perform the test according to thin-layer chromatography. Spot 5 μL each of the sample solution and standard solution on a plate prepared with silica gel for thin-layer chromatography. Develop the plate with benzene to a distance of about 10 cm, and air-dry the plate. Spray antimony (III) chloride test solution to this plate, and read and compare the corresponding position of the major spot developing blue obtained from the sample and reference standard.

Determine the absorbances by applying Method 1, however, when the wavelength of maximum absorption does not lie between 325~328 nm, or when the absorbance ratio is not within the range of ± 0.030 of the values in table, apply Method 2.

Table

λ (nm)	Retinol Acetate	Palmitic Acid Retinol
300	0.578	0.590
310	0.815	0.825
320	0.948	0.950
326	1.000	1.000
330	0.972	0.981
340	0.786	0.795
350	0.523	0.527

B. Method 2

Unless otherwise specified, weigh a sample containing not less than 500 Units of vitamin A, and not more than 1 g of fat, to three significant digits, record the value, transfer to a flask, and add 30 mL of aldehyde-free ethanol and 1 mL of a solution of pyrogallol in ethanol (1 \rightarrow 10). Then, add 3 mL of a solution of potassium hydroxide (9 \rightarrow 10), attach a reflux condenser, and

heat on a water bath for 30 minutes to saponify. Cool quickly to ordinary temperature, add 30 mL of water, transfer to a separator A, wash the flask with 10 mL of water and then 40 mL of diethyl ether, transfer the washings to the separator A, shake well, and allow to stand. Transfer the water layer so obtained to a separator B, wash the flask with 30 mL of diethyl ether, add the washing to the separator B, and extract by shaking. Transfer the water layer to a flask, add the diethyl ether layer to the separator A, transfer the water layer in the flask to the separator B, add 30 mL of diethyl ether, and extract by shaking. Transfer the diethyl ether layer so obtained to the separator A, add 10 mL of water, allow the separator A to stand after gentle turning upsidedown 2 or 3 times, and remove the water layer. Wash the content of the separator A with three 50 mL portions of water with increasingly vigorous shaking as the washing proceeds. Further wash with 50 mL portions of water until the washing no longer shows a pink color with phenolphthalein test solution, and allow to stand for 10 minutes. Remove remaining water as far as possible, transfer the diethyl ether to an Erlenmeyer flask, wash the separator with two 10 mL portions of diethyl ether, add 5 g (4.5~5.4 g) of anhydrous sodium sulfate to the flask, mix by shaking, and transfer the diethyl ether to a round-bottomed flask by decantation. Wash the remaining sodium sulfate in the flask with two or more 10 mL portions of diethyl ether, and transfer the washings to the flask. Evaporate the diethyl ether in a water bath at 45 °C while swirling the flask, using an aspirator, to about 1 mL, add isopropanol within 30 seconds to make a solution exactly containing 6~10 vitamin A Units per mL, and designate the solution as the sample solution. Determine the absorbances, A_1 , A_2 , and A_3 at 310 nm, 325 nm and 334 nm respectively (10 mm).

Units of vitamin A in 1 g of the sample = $E_{1\text{cm}}^{1\%}(325\text{ nm}) \times 1,830$

$$E_{1\text{cm}}^{1\%}(325\text{ nm}) = \frac{A_2}{W} \times \frac{V}{100} \times f$$

$$f = 6.815 - 2.555 \times \frac{A_1}{A_2} - 4.260 \times \frac{A_3}{A_2}$$

f: Correction Factor

V: Total volume (mL) of the sample solution

W: Amount (g) of sample in V mL of the sample solution

(33) Vitamin D Assay

Vitamin D assay is a method to determine vitamin D in crude material for preparation of vitamin D₃ oil, that of vitamin D powder and other vitamin D in feed additives using gas chromatography. This assay is applied when the mass ratio of vitamin E (*dl*- α -tocopherol acetate) to vitamin D is not more than 2,500. Regarding vitamin D powder preparation, weigh an amount

containing 8,000 vitamin D I. U. to three significant digits, record the value, add 20 mL of sodium ascorbate solution (1 → 20), attach a condenser, make this solution slimy or milky in a water bath, perform the test using this solution as the sample. In the case where sterols are mixed together, perform the removing-sterin treatment with siliceous earth-digtonin column. Evaporate the 50 mL of benzene layer which is obtained by saponification and extraction of the sample under a reduced pressure, add 3 mL of *n*-hexane to the residue to dissolve. Transfer this solution into a siliceous earth-digtonin column, add further *n*-hexane, downflow at a flow rate of 0.5 mL/min, and collect about 30 mL of the eluate. Evaporate the solvent of this eluate, to the residue add 1.0 mL of acetone with transfer pipet to dissolve, perform the following tests by using this solution as the sample solution for thin layer chromatography below.

One vitamin D I. U. is equivalent to 0.025 µg of vitamin D₃.

Reagents · Test solution:

Aldehyde-free ethanol: To 1 L of ethanol [Special class] add 5 mL of 50 % potassium hydroxide solution and 5 g (4.5~5.4 g) of zinc powder, reflux for about 2 hours, distill, and collect the distillate discarding both the first and the last 10 %.

n-Hexane [Special class]: Determine the absorbances using water as the control solution (10 mm), use not more than $E_{1\text{cm}}^{1\%} = 0.3$ at a wavelength of 240 nm to 250 nm.

Benzene: Distill benzene [Special class] before use, and collect the distillate discarding both the first and the last 10 %.

Acetone: Add potassium permanganate to acetone [Special class] in small portions, and shake.

When the mixture keeps its purple color after standing for 2 to 3 days, distill, and dehydrate with freshly ignited anhydrous potassium carbonate. Distil by using a fractionating column under protection from moisture, and collect the fraction distilling at 56 °C.

Silica gel: For thin-layer chromatography (with fluorescent indicator)

Stigmasterol acetate: Dissolve 0.54 g (0.535~0.544 g) of stigmasterol [Special class] in 4.8 mL of pyridine, add 1.2 mL of glacial acetic acid, warm in a water bath at 60~70 °C for 1 hour, and allow to stand overnight at room temperature. Pour this mixture into water, filter to obtain the precipitate, wash this precipitate with water, recrystallize with ethanol (melting point: 143~145 °C).

Use the reagents, except the above reagents, that meet the corresponding requirements of special class of the Japan Industrial Standards (JIS).

Reference Standards · Standard Solutions:

Vitamin D₂ reference standard, Ergocalciferol in Japanese Pharmacopoeia: When determine the absorbances at 265 nm, use vitamine D₂ reference standard which is not less than $E_{1\text{cm}}^{1\%} = 465$ (0.01 g, ethanol, 1,000 mL).

Vitamin D₃ reference standard, Cholecalciferol in Japanese Pharmacopoeia: When determine the absorbances at 265 nm, use vitamin D₃ reference standard which is not less than $E_{1\text{cm}}^{1\%} = 470$ (0.01 g, ethanol, 1,000 mL).

Vitamin D·pre-D solution: Dissolve 5 mg (4.5~5.4 mg) of vitamin D reference standard in 10 mL of ethylene dichloride, and reflux for 30 minutes in a water bath. Prepare before use.

Internal standard solution, Solution A: Weigh 0.050 g (0.0495~0.0504 g) of stigmaterol acetate, add acetone to dissolve, transfer in a 100 mL volumetric flask, and add acetone to make exactly 100 mL. Preserve in a cool and dark place.

Solution B: Measure 10 mL of solution A with transfer pipet, transfer to a 100 mL volumetric flask, and add acetone to make exactly 100 mL. Prepare before use.

Vitamin D standard solution: Dissolve 0.040 g (0.0395~0.0404 g) of vitamin D in acetone, transfer to a 100 mL volumetric flask, and add acetate to make 100 mL. Measure 10 mL of this solution with transfer pipet, place in a 100 mL volumetric flask, add 10 mL of the internal standard solution A with transfer pipet, add acetone to make exactly 100 mL, and use this solution as vitamin D standard solution. Prepare before use.

Preparation of siliceous earth-digtonin column:

Add 10 mL of water to 600 mg (599.5~600.4 mg) of digtonin, warm to dissolve, allow to stand for about 1 hour. Add 5 mL of this solution to 10 g (9.5~10.4 g) of siliceous earth for chromatography, mix homogeneously, pour 3 g (2.5~3.4 g) of this mixture into a brown glass tube (10 mm × 300 mm) with *n*-hexane, and draw off most of the *n*-hexane.

Procedure:

All procedures should be carried out quickly with light-resistant containers.

Weigh the amount of the sample containing 8,000 vitamin D I.U. to three significant digits, record the value, transfer in a flask, and add 50 mL of aldehyde-free ethanol and 20 mL of pyrogallol in ethanol (2 → 10). Add 8 mL of potassium hydroxide solution (9 → 10), attach a reflux condenser, heat for 30 minutes in a water bath for saponification. Cool quickly to a room temperature, add 100 mL of benzene with transfer pipet, shake well, transfer to a separator. Add 40 mL of potassium hydroxide test solution, shake vigorously for 15 seconds, allow to stand, and remove the water layer.

To the benzene layer add 40 mL of potassium hydroxide solution (3 → 100), shake and allow to stand, remove the water layer. To the benzene layer add 40 mL of water, allow the separator to stand after gentle turning upsidedown 2~3 times, and remove the water layer. Wash the content of the separator with 40 mL portions of water with increasingly vigorous shaking as the washing proceed. Further wash with 40 mL portions of water until the washing no longer shows pink color with phenolphthalein test solution, remove remaining water as far as possible. Put dried round

filter paper with cut (diameter: 9 cm) in the separator, and shake until the benzene layer becomes clear.

Measure 50 mL of the benzene layer with transfer pipet, place in a 100 mL Erlenmeyer flask with a glass stopper, and evaporate the benzene in a water bath at 40 °C while swirling the flask, using an aspirator. Add 1.0 mL of acetone to the residue with transfer pipet, shake well to dissolve, use this solution as the sample solution for thin-layer chromatography. Measure 0.2 mL of this sample solution with transfer pipet or micropipette, spot on a plate prepared with silica gel for thin-layer chromatography (with fluorescent indicator). Separately, spot vitamin D·pre-D solution on the corner of the same plate. Then, develop the plate with a mixture of *n*-hexane-ethyl acetate (4:1) to a distance of 15 cm, and air-dry the plate. Examine under ultraviolet light (DWL 254 nm), take off the spots of vitamin D and pre D obtained with a stainless steel micro spatula within 5 minutes, and transfer in a 50 mL beaker.

Extract with 6 portions of 5 mL of acetone, and filter into a 50 mL round-bottomed with a filter paper. Wash the filter paper with a small quantity of acetone, and mix the washings with the filtrate. Evaporate the acetone extract in a water bath at 40 °C while swirling the flask, using an aspirator. Cool quickly to a room temperature, add 0.50 mL of the internal standard solution B to the residue with transfer pipet or micropipette to dissolve, and use this solution as the sample solution.

Perform a test according to Gas chromatography method under the following conditions, obtain the peak area of both pyro-D and stigmaterol acetate by Width at half-height method, and determine the area ratio.

Vitamin D I. U. in 1 g of the sample = $S \times$

$\frac{\text{the ratio of the peak area of pyro D to internal standard substance in the sample solution}}{\text{the ratio of the peak area of pyro D to internal standard substance in standard solution}} \times V \times \frac{1}{W}$

S: Vitamin D I. U. in 0.5 mL of standard solution (1 mL of standard solution contains 1,600 of vitamin D I. U.)

V: The dilution number (In the case above: $2 \times 5 = 10$)

W: The number of gram in the sample solution.

The operating conditions are as follows.

Detector: A hydrogen flame-ionization detector

Separation column: Glass column, 4 mm in inside diameter and 1.5 m in length (1.5 % methyl phenyl silicone-AW-DMCS, 80~100 mesh)

Temperature: 225 °C in the separation column, 250 °C in the injection port and 300 °C in the detector.

Injection volume of sample: 5 µL

Carrier gas and flow rate: Nitrogen, adjust the flow rate of nitrogen so that internal standard substance appears in about 40~60 minutes later.

(34) Boiling Point and Distilling Range Test

The boiling point and distilling range are determined by Method 1 or Method 2 as described herein, unless otherwise specified. Boiling point is the temperature shown between when the first 5 drops of distillate leave the tip of condenser and when the last liquid evaporates from the bottom of the flask. Distilling range test is done to determine the volume of distillate which has been collected in the range of temperature directed in the monograph.

Method 1: This method is applied to a sample for which the permissible range of boiling temperature is smaller than 5 °C.

Apparatus:

Use the apparatus illustrated in figure.

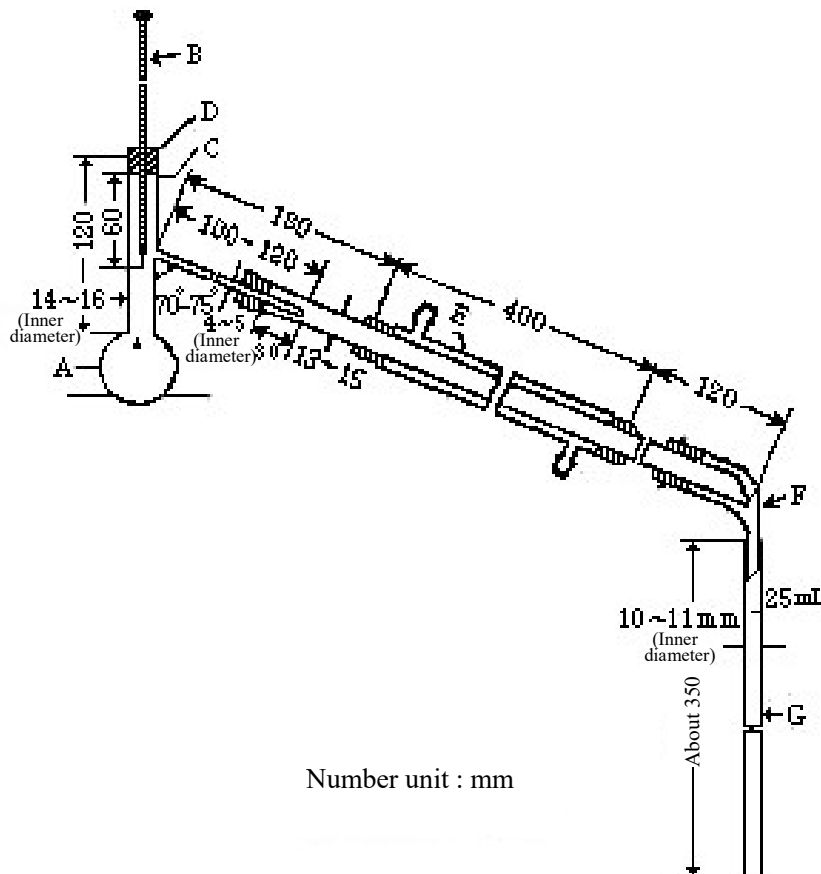

- A: Distilling flask
- B: Thermometer with an immersion line
- C: Immersion line

D: Cork stopper

E: Condenser

F: Adapter

G: Volumetric cylinder (25 mL, graduated to 0.1 mL)

Procedure:

Measure 25 mL of the sample, whose temperature is previous noted, using measuring volumetric cylinder G graduated in 0.1 mL, and transfer it to a distillation flask A of 50 to 60 mL capacity. Use this cylinder as a receiver for the distillate without rinsing out any of the adhering liquid. Put boiling tips into the distilling flask A, insert a thermometer B with an immersion line so that its immersion line C is on a level with the lower end of cork stopper D and the upper end of its mercury bulb is located in the center of the delivery tube, and connect condenser E with the distilling flask A and adapter F with the condenser E. Insert the open end of F in to the mouth of cylinder G (receiver) so that air can pass through slightly. Use a hood with a height sufficient to shield A, and heat A with a suitable heat source. Unless otherwise specified, distill the liquid sample by the application of heat, at a rate of 4~5 mL per a minute of distillate in the case of liquids whose boiling temperature to be determined is lower than 200 °C and a rate of 3~4 mL per minute in the case of liquids whose boiling temperature is 200 °C or over. For the distilling range test, bring the temperature of distillate to the temperature at which the volume was originally measured, and measure the volume of distillate.

Liquid that begin to distil below 80 °C are cooled to between 10 and 15 °C before measuring the volume, and the receiving cylinder is kept immersed in ice up to a point 25 mm from the top during the distillation.

Collect the observed temperature for any variation in the barometric pressure from the normal (100 kPa), by allowing 0.1 degree for each 0.36 kPa of variation, adding if the pressure is lower, or subtracting if higher than 100 kPa.

Method 2: This method is applied to the sample for which the permissible range of boiling temperature is 5 °C or more.

Apparatus:

The same apparatus as described in Method 1 is used. However, use a 200 mL distilling flask A with a neck 18~24 mm in inside diameter having a delivery tube 5~6 mm in inside diameter.

Procedure:

Measure 100 mL of the sample, whose temperature is previously noted, using a volumetric cylinder graduated in 1 mL, and carry out the distillation in the same manner as in Method 1.

(35) Melting Point Determination

Melting point is a temperature measured by the following methods. When the range of melting point of a substance is specified, the melting point of the substance may be within the range.

The testing method may be divided into the following two methods according to physical and chemical properties of feed additives. Unless otherwise specified, measurement is performed by Method 1.

Procedure:**A. Method 1**

This method is applied to those substances of which can be pulverized.

Pulverize the sample to a fine powder, and unless otherwise specified, dry in a desiccator (silica gel) for 24 hours. When it is specified to do the test after drying, dry the sample under the conditions specified in the monograph before measurement. Place the sample in a dried capillary tube H, and pack it tightly so as to form a layer about 2.5~3.5 mm high by dropping a capillary repeatedly, with the closed end of H down, through a glass tube, about 700 mm long, held vertically on a glass or porous plate.

Heat bath fluid B until the temperature rises to about 10 °C below the expected melting point, place the thermometer D in the bath with the immersion line at the same level as meniscus of the bath fluid, and insert capillary tube H into a coil spring G so that the packed sample is placed in a position corresponding to the center of the mercury bulb of the thermometer D. Continue heating to raise the temperature at a rate of approximately 3 °C per minute until the temperature rises to 5 °C below the expected melting point, then carefully regulate the rate of temperature increase to 1 °C per minute.

Read the thermometer indication of the instantaneous temperature at which the sample liquefies completely and no solid is detectable in the capillary, and designate the indicated temperature as the melting point of the sample specimen. Use apparatus illustrated in figure. Use bath fluid, thermometer with an immersion line and capillary tube specified in the following.

Bath fluid: Usually use clear silicone oil having a viscosity of 50 to 100 mm²/s at an ordinary temperature.

Thermometer with an immersion line: For melting points lower than 50 °C, use a thermometer Type 1; for 40 to 100 °C, Type 2; for 90 to 150 °C, Type 3; for 140 to 200 °C, Type 4; for 190 to 250 °C, Type 5; for 240 to 320 °C, Type 6.

Capillary tube: Use a hard glass capillary tube 120 mm long, 0.8 to 1.2 mm in inside diameter and 0.2 ~0.3 mm thick, with one end closed.

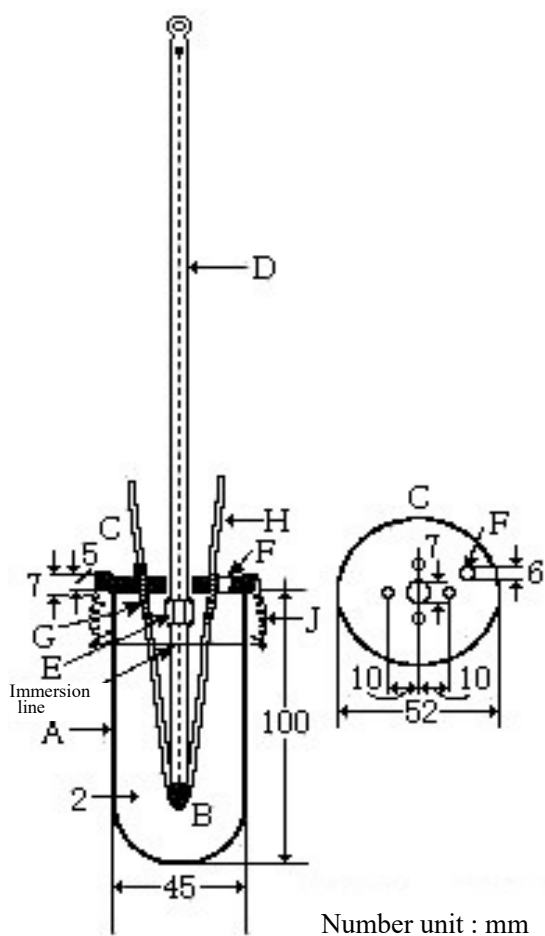

- A: Heating vessel of hard glass
- B: Bath fluid
- C: Polytetrafluoroethylene stopper
- D: Thermometer with an immersion line
- E: Thermometer-fastening spring
- F: Vent for adjustment of the bath fluid volume
- G: Coil spring
- H: capillary tube
- J: Spring for fastening polytetrafluoroethylene stopper

B. Method 2

This method is applied to substances such as fats, fatty acid, paraffins or waxes and something insoluble in water and unavailable readily pulverized.

Carefully melt the sample at as low temperature as possible, and taking care to prevent bubbles, introduce it into a capillary tube (opened both edge, described in Method 1) to a height of about 10 mm. Allow the capillary containing the sample to stand for 24 hours at

below 10 °C, or for at least 1 hour in contact with ice, holding the capillary so that the sample can not flow out. Then attach the capillary to the thermometer by means of a rubber band so that the absorbed sample is located at a position corresponding to the center of mercury bulb, and put it in a water-containing beaker to such a position that the lower edge of the sample is located 30 mm below the water surface. Heat the beaker with constant stirring until the temperature rises to 5 °C below the expected melting point. Then regulate the rate of temperature increase to 1 °C per minute. The temperature at which the sample begins floating in the capillary is taken as the melting point of the sample specimen.

(36) Sulfate Limit Test

Sulfate Limit Test is a limit test for sulfate contained in samples.

In each monograph, the permissible limit for sulfate (as SO₄) is described in terms of percentage (%) in parentheses.

Procedure:

Unless otherwise specified, proceed by the following method.

Transfer the quantity of the sample, directed in the monograph, to a Nessler tube, dissolve it in sufficient water, and add water to make 40 mL. Add 1 mL of dilute hydrochloric acid and water to make 50 mL, and use this solution as the sample solution. Transfer the volume of 0.005 mol/L sulfuric acid, directed in the monograph, to another Nessler tube, add 1 mL of dilute hydrochloric acid and water to make 50 mL, and use this solution as the control solution. When the sample solution is not clear, filter both solutions according to the same procedure.

Add 2 mL of barium chloride test solution to the sample solution and to the control solution, mix well, and allow to stand for 10 minutes. Compare the turbidity produced in both solutions against a black background by viewing downward or transversely.

The turbidity produced in the sample solution should not be thicker than that of the control solution.

(37) Readily Carbonizable Substances Test

Readily Carbonizable Substances Test is a method to examine the minute impurities contained in samples, which are readily colored by addition of sulfuric acid.

Procedure:

Before use, wash the Nessler tubes thoroughly with sulfuric acid for readily carbonizable substances. Unless otherwise specified, proceed as follows. When the sample is solid, place 5 mL of sulfuric acid for readily carbonizable substances in a Nessler tube, to which add a quantity of the finely powdered sample, little by little, as directed in the monograph, and dissolve it

completely by stirring with a glass rod. When the sample is liquid, transfer a volume of the sample, as directed in the monograph, to a Nessler tube, add 5 mL of sulfuric acid for readily carbonizable substances, and mix by shaking. If the temperature of the content of tube rises, cool the content; maintain it at the standard temperature, if the reaction may be affected by the temperature. Allow to stand for 15 minutes, and compare the color of the liquid with that of the matching fluid in the Nessler tube specified in the monograph, by viewing transversely against a white background.

(38) Paper Chromatography

Paper Chromatography is a method to separate each ingredient by developing a mixture in a mobile phase, using a filter paper, and is applied for Identification, purity test, etc. of substances.

Procedure:

Unless otherwise specified, proceed by the following method.

Designate a line about 50 mm distant from the bottom of rectangular filter paper as the starting line (width: 20~30 mm, length: 400 mm), spot the directed volumes of the sample solution in the monograph using micropipettes or capillaries at the center on this line, and air-dry. Suspend this filter paper in the container 500 mm in height in which has been placed the developing solvent and saturated with its vapor, avoiding contact with the inside wall, the developing solvent is placed up to 10 mm in height from the bottom beforehand, seal the container. Develop it at ordinary temperature.

When the solvent front has ascended from the starting line to the distance direction in the monograph, remove the paper from the container. Put a mark at the solvent front within 30 seconds. After air-drying, observe the location, color, etc., of each spot by the method specified in the monograph. Calculate the R_f value by using the following equation.

$$R_f = \frac{\text{distance from the starting line to the center of the spot}}{\text{distance from the starting line to the solvent front}}$$